

# **A Guide To Interpreting Stream Survey Reports**

**Scott C. Foster  
Charles H. Stein  
Kim K. Jones**

**Edited by  
Patricia A. Bowers**

**Aquatic Inventories Project  
Natural Production Program  
Oregon Department of Fish And Wildlife  
2501 SW First Street  
PO Box 59  
Portland, OR  
97207**



# Table of Contents

<b>1.0</b>	<b><u>HOW TO USE THIS GUIDE</u></b> .....	<b>1</b>
	<b><u>REACH REPORT</u></b> .....	<b>2</b>
	<b><u>PART A - STREAM LEVEL ANALYSES</u></b> .....	<b>3</b>
<b>2.0</b>	<b><u>VALLEY AND CHANNEL SUMMARY</u></b> .....	<b>3</b>
2.1	<u>Valley Characteristics and Channel Morphology</u> .....	3
2.2	<u>Channel Characteristics And Channel Dimensions</u> .....	7
<b>3.0</b>	<b><u>RIPARIAN, BANK AND WOOD SUMMARY</u></b> .....	<b>11</b>
3.1	<u>Land Use and Riparian Vegetation Codes</u> .....	11
3.2	<u>Bank Condition and Shade</u> .....	12
3.3	<u>Large Woody Debris Summary</u> .....	13
	<b><u>HABITAT UNIT REPORT</u></b> .....	<b>15</b>
<b>4.0</b>	<b><u>HABITAT UNIT SUMMARY</u></b> .....	<b>17</b>
4.1	<u>Habitat Detail</u> .....	17
4.2	<u>Habitat Summary</u> .....	18
4.3	<u>Pool Summary</u> .....	19
4.4	<u>Stream Summary</u> .....	19
	<b><u>RIPARIAN ZONE REPORT</u></b> .....	<b>20</b>
<b>5.0</b>	<b><u>RIPARIAN ZONE SUMMARY</u></b> .....	<b>22</b>
5.1	<u>Riparian Zone Vegetation Summary</u> .....	22
5.2	<u>Canopy closure, ground cover, and predominant landform in each zone</u> .....	23
5.3	<u>Riparian Zone Vegetation Detail</u> .....	25
<b>6.0</b>	<b><u>STREAM PROFILE GRAPHS</u></b> .....	<b>26</b>
6.1	<u>Percent Shade</u> .....	27
6.2	<u>Percent of Substrate Silt, Organics, and Sand</u> .....	28
6.3	<u>Percent Of Substrate Gravel</u> .....	29
6.4	<u>Percent Of Substrate Bedrock</u> .....	30
6.5	<u>Large Boulders Per 100 Meters</u> .....	31
6.6	<u>Number Of Deep Pools</u> .....	32
6.7	<u>Pieces and Volume Of Large Wood</u> .....	33
6.8	<u>Key Pieces Of Large Wood</u> .....	34
<b>7.0</b>	<b><u>HABITAT BAR GRAPHS</u></b> .....	<b>36</b>
<b>8.0</b>	<b><u>ADDITIONAL MATERIAL</u></b> .....	<b>37</b>
8.1	<u>Cover Document</u> .....	37
8.2	<u>Comment Summary</u> .....	38
8.3	<u>Maps</u> .....	39

8.4	<a href="#">Photo Sheets</a>	40
8.5	<a href="#">Calibration Worksheet</a>	40
<b><a href="#">PART B – WATERSHED LEVEL ANALYSIS</a></b>		<b>41</b>
<b>9.0</b>	<b><a href="#">BASIN SUMMARY</a></b>	<b>41</b>
9.1	<a href="#">Reach Summary Tables</a>	41
9.2	<a href="#">Frequency Distributions</a>	41
9.3	<a href="#">Benchmarks</a>	41
<b><a href="#">APPENDIX I: SUMMARY OF ODFW STREAM SURVEY METHODOLOGY</a></b>		<b>47</b>
<b><a href="#">APPENDIX II: GLOSSARY</a></b>		<b>49</b>
<b><a href="#">LITERATURE CITED</a></b>		<b>55</b>

***“You cannot step into the same river twice;  
for other waters are ever flowing.”***

**— Heraclitus**

## **1.0 HOW TO USE THIS GUIDE**

This guide will help the reader interpret the graphical and tabular results of the stream survey data analysis. The guide is written for an ever-widening audience of private citizens, land managers, watershed councils, students, and other parties interested in obtaining information about Oregon streams surveyed with methods developed by the Oregon Department of Fish and Wildlife. The methodology used in these surveys is a modified version of similar methods developed by Bisson, et al. (1982), and Hankin and Reeves (1988). These survey methods are most useful for small to medium-sized streams, usually those small enough to walk in using hip waders.

This guide is designed as a stand-alone document, but the user will benefit if using it in conjunction with the Aquatic Inventories Project Stream Survey Methods Manual (Moore et al., 1997; hereafter referred to as the Methods Manual) for a more thorough understanding of data collection procedures. The best way to interpret stream survey data, however, is to join a survey crew in the process of conducting a survey. You will gain firsthand knowledge of how the data collection methods attempt to measure the quantity and quality of fish habitat.

While the ODFW stream survey methods measure many aspects of instream and streamside physical habitat, some important habitat parameters are beyond the scope of this form of survey. Those parameters include water quality, both chemical and physical, water quantity, and macroinvertebrate production and distribution.

Each section of the stream survey report is described in detail within this guide. Part A interprets analysis of individual streams, while Part B addresses summaries of streams within a watershed. Vocabulary terms are presented in **bold** type and are defined in the glossary section at the end of the training packet. Key concepts are noted in boxes. The meaning of each numerical or statistical measurement is described in relationship to stream ecology and fish habitat suitability.

Because a particular stream survey's objectives and data analysis may be very specific, certain sections included here may be absent from some analyses and reports.

Citation: Foster, S.C., C.H. Stein, and K.K. Jones. 2001. A guide to interpreting stream survey reports. *Edited by P.A. Bowers*. Information Reports 2001-06. Oregon Department of Fish and Wildlife, Portland.

# REACH REPORT

OREGON DEPT. FISH AND WILDLIFE  
HABITAT INVENTORY Report Date: 05/04/99

GREEN CREEK #956  
Survey Date: 06/23/98

## REACH SUMMARY

REACH 1 REACH 1  
T17S-R9W-16NE

3

**Valley and Channel Summary**

Valley Characteristics (Percent Reach Length)

<u>Narrow Valley Floor</u>	<u>Broad Valley Floor</u>
Steep V-shape 0	Constraining Terraces 100
Moderate V-shape 0	Multiple Terraces 0
Open V-shape 0	Wide Floodplain 0

Valley Width Index avg: 3.4 range: 2.0-6.0

1

(p. 3)

4

**Channel Morphology (Percent Reach Length)**

<u>Constrained</u>	<u>Unconstrained</u>
Hillslope 0	Single Channel 0
Bedrock 0	Multiple Channel 0
Terrace 0	Braided Channel 0
Alt. Terrace/Hill 100	
Landuse 0	

**Channel Characteristics**

<u>Type</u>	<u>Length(m)</u>	<u>Area (m2)</u>	<u>Dry Units</u>
Primary	1,160	7,071	0
Secondary	46	107	2

**Channel Dimensions (m)**

<u>Wetted</u>		<u>Active</u>	<u>Floodprone</u>	<u>First Terrace</u>
Width 6.0	Width	10.9	14.6	16.3
Depth 0.27	Height	0.6	1.1	1.4
	W:D ratio	19.6	Entrenchment	1.3

Stream Flow Type: MF Water Temp: 13.0-13.0°C  
Avg. Unit Gradient: 1.2% Habitat Units/100m: 5.3

2

(p. 3)

6

**Riparian, Bank, and Wood Summary**

	<u>Primary</u>	<u>Secondary</u>
Land Use:	LT	MT
Riparian Vegetation:	D30	S

7

(p. 11)

8

**Bank Condition and Shade**

<u>Bank Status</u>	<u>Percent Reach Length</u>	<u>Shade (% of 180)</u>
Actively Eroding	8%	Reach avg: 89%
Undercut Banks	4%	Range: 62-100

**Large Woody Debris**

	<u>Total</u>	<u>Total/100m</u>
All pieces (≥3m x 0.15m)	99	8.5
Volume (m <sup>3</sup> )	76	6.5
Key pieces (≥10m x 0.6m)	1	0.1

9

(p. 13)

# PART A - STREAM LEVEL ANALYSES

## Reach Report

A *Reach Summary* is prepared for each reach. It describes and quantifies valley and channel characteristics, riparian vegetation, land use, bank conditions, and shade potential throughout the reach.

### 2.0 VALLEY AND CHANNEL SUMMARY

***A discussion of the stream's valley and stream channel requires that we expand our attention beyond the stream itself, and consider the broader landscape context in which the stream exists. The valley contains the stream channels, and the channels contain the stream.***

**1** A *Valley and Channel Summary* is prepared for each reach. It describes how the stream channel fits into the valley. The Valley and Channel Summary describes characteristics of the valley such as its cross-sectional shape, and its width compared to the width of the **active channel**. Characteristics of the channel, such as its shape, adjacent landforms, dimensions, gradient, and amount of secondary channels, are also described.

REACH 1	T17S-R9W-16NE	REACH 1
<b>Valley and Channel Summary</b>		
Valley Characteristics (Percent Reach Length)		
<u>Narrow Valley Floor</u>		<u>Broad Valley Floor</u>
Steep V-shape	0	Constraining Terraces
Moderate V-shape	0	Multiple Terraces
Open V-shape	0	Wide Floodplain
Valley Width Index avg: 3.4		range: 2.0-6.0

### 2.1 Valley Characteristics and Channel Morphology

***Valley characteristics and channel morphology are interrelated. They provide information about how the stream fits into, and interacts with, its valley.***

***Active channel width (ACW) provides a reference to stream size regardless of flow level at the time of the survey. ACW is the distance across the channel at "bank full" flow. Active channel width is used to evaluate channel and valley characteristics.***

**2** ***Valley width index (VWI) is the number of active channels that fit between the hillslopes across the valley floor. It reflects the potential for the stream to meander back and forth across the valley floor or to create new channels within the valley.***

What it means:

**3** Stream channels exist within the stream valley. The stream valley can fall into one of two general functional categories: narrow valley floor or broad valley floor.

A narrow valley floor is less than 2.5 times the active channel width ( $VWI < 2.5$ ). Steep, moderate, and open V-shapes reflect the steepness of the valley's hillslopes. Stream channels in narrow valleys are always constrained from lateral movement by either adjacent hillslopes or bedrock walls.

**4** Channel constraint refers to the ability of the stream to move laterally within the valley. In constrained channels, stream flows are confined to the existing channel in all but the highest flood flows. In unconstrained channels, the stream can move and meander throughout the valley over time. The height and proximity of adjacent landforms determine whether a channel is constrained or unconstrained.

A broad valley floor is greater than 2.5 times the active channel width ( $VWI > 2.5$ ). Stream channels in broad valleys may be either constrained or unconstrained, depending upon the adjacent landforms. The features that constrain the lateral movement of the stream may be some combination of high terraces or hillslopes, or the stream may be constrained by land use features such as roadbeds, railways, dikes, and others. If constraining terraces or land use features are present within a valley, they must be both high and close to the stream channel to constrain its lateral movement.

Multiple terraces vary in height and “stair step” out away from the stream channel. A wide floodplain is an area inundated by normal winter high flows. Unconstrained channels occur where there is no high or close constraining feature, and can form as a single channel, as multiple channels that are fairly parallel to one another, or as a complex of interwoven braided channels. In unconstrained configurations, water flow is not restricted to any particular channel, and can move and meander throughout the stream valley over time.

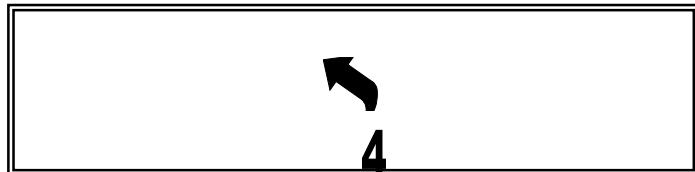

# VALLEY FORM

## NARROW VALLEY FLOOR VWI < 2.5

## BROAD VALLEY FLOOR VWI > 2.5

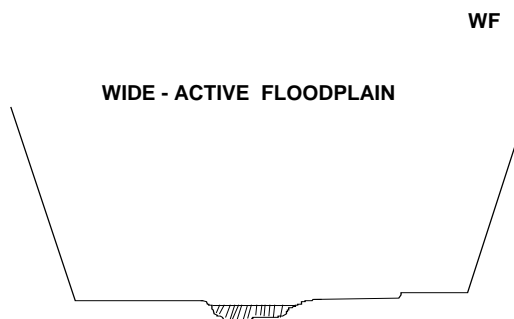
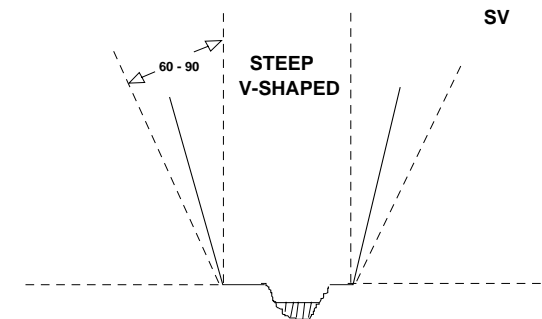
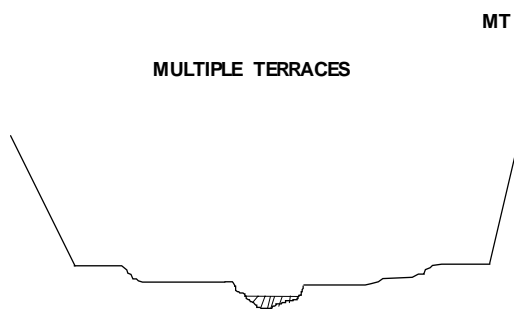
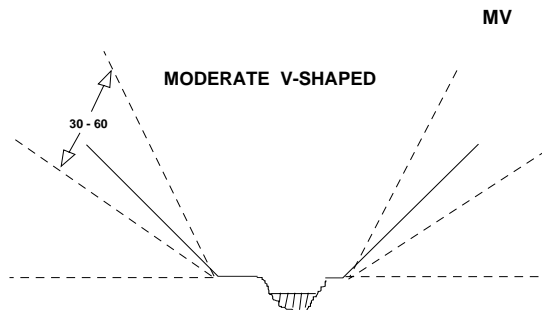
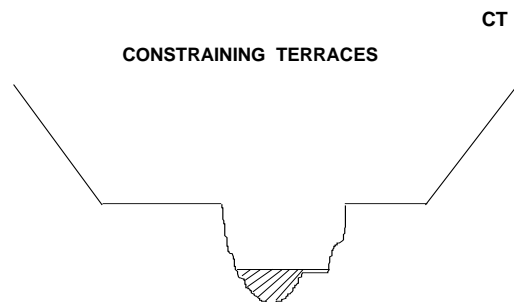
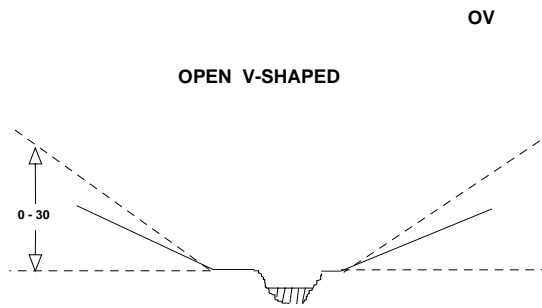



# CONSTRAINED AND UNCONSTRAINED CHANNEL MORPHOLOGY

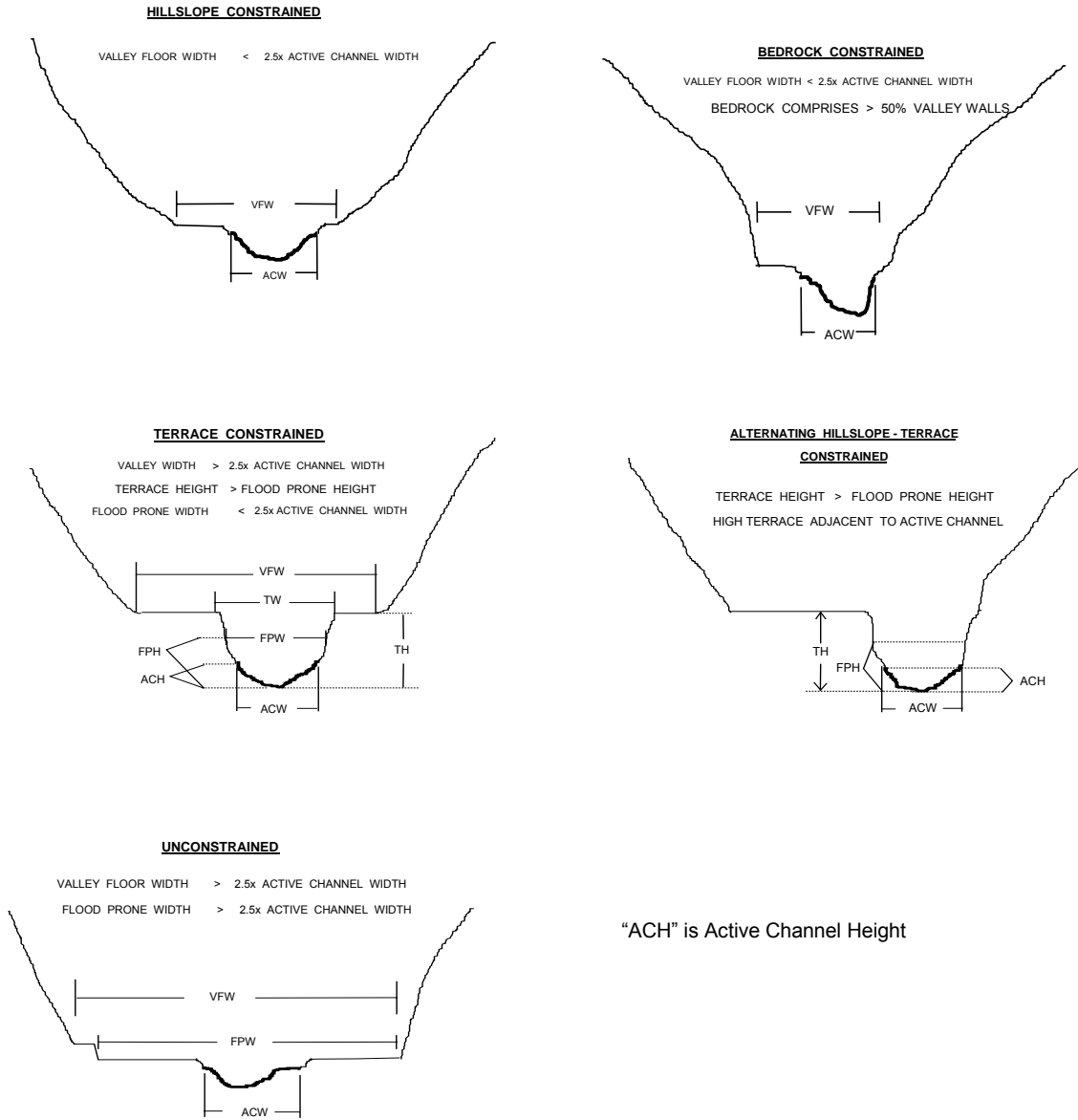

"ACH" is Active Channel Height

- **How valley characteristics and channel morphology are determined:**

The survey crew determines the valley characteristics and channel morphology primarily by visually referencing the channel and surrounding landforms as they move up the stream. United States Geological Survey (USGS) topographic maps also help surveyors recognize these characteristics. The percent of the total length of the reach in each configuration is determined during data analysis and is reported in the "Valley and Channel Summary" section in the Reach Report.

**Valley characteristics and channel morphology are especially significant during high flow events. During high flows, streams may form secondary channels on broad valley floors. Secondary channels provide important resting and over-wintering habitat for fish.**

- **Significance for fish habitat:**

Most changes in stream channels occur during high flow events. Additional channels are formed when floodwaters flow over the tops of the terraces and find a new route. The changes allow the stream to dissipate the energy of the high flows, especially in broad valley floors. Fish are more likely to find over-wintering habitat where they can escape from high velocity winter flows. **Secondary channels** help divert some of the flow and reduce the overall velocity.

Wide floodplains and unconstrained channels store great amounts of water during high flows. This water is slowly released back into the stream during the dry summer months, augmenting the **base flow** supplying water for fish habitat during dry seasons.

## 2.2 Channel Characteristics And Channel Dimensions

**Channel characteristics and dimensions describe the stream with respect to the adjacent landforms. These measurements indicate the degree of channel constraint and the ability of the stream to interact with its floodplain. Interactions with floodplains enhance bank stability, secondary channel formation, riparian vegetation, and the shade it produces. These variables contribute to habitat complexity.**

- **What it means:**

5

Channel characteristics and channel dimensions describe lengths, widths, depths, heights, and gradients of the stream channels and their associated floodplains. All lengths are measured in (or converted to) meters and all areas are given in square meters. Temperatures are recorded in degrees Celsius. Gradients are measured in percent slope (for example, 100% slope equals a 1.0 meter elevation gain over a distance of 1.0 meter. Slopes greater than 100% are possible).

Channel Characteristics				
Type	Length (m)	Area (m <sup>2</sup> )	Dry Units	
Primary	1,160	7,071	0	
Secondary	46	107	2	
Channel Dimensions (m)				
Wetted		Active	Floodprone	First Terrace
Width	6.0	Width 10.9	14.6	16.3
Depth	0.27	Height 0.6	1.1	1.4
		W:D ratio 19.6	Entrenchment 1.3	
Stream Flow Type: MF		Water Temp: 13.0-13.0°C		
Avg. Unit Gradient: 1.2%		Habitat Units/100m: 5.3		

5

Primary and secondary channels. The length and wetted area are summed for both the **primary channel** and all secondary channels within a particular reach. The numbers of dry units within the primary and secondary channels are also recorded.

Wetted width and depth. The average width and depth of the wetted portion of the stream channel are calculated for the entire reach.

Active channel width and height. Active channel width is the distance across the channel at average bankfull flow (the high water mark that occurs on average about every 1.5 years). The

height of the active channel is measured from the bottom of the channel to the height at bankfull flow.

Width to depth ratio. Dividing the active channel width by the active channel height determines the width to depth ratio. The width to depth ratio is an indicator of habitat quality. Relatively deep, narrow stream channels tend to provide better fish habitat than shallow wide channels.

Floodprone width and height. The average floodprone width and height are measurements indicating the height above and width beyond the stream channel that would be inundated by the highest flood event likely to occur during a 50-year period.

First terrace width and height. The height to and width between the first terraces, if present, are given. If no terraces are present (hillslopes extend to the active channel margin), these values are zeroes. When compared to the floodprone measurements, the terrace measurements indicate whether the stream is constrained by the terraces. For example, if the floodprone height and width are less than the terrace height and width, and the floodprone width is less than 2.5X the active channel width, the stream is bounded by a constraining terrace or hillslopes on both sides. Alternatively, if the floodprone height and width are greater than the terrace measurement, flood events are able to overflow the terrace. Comparisons of the floodprone vs. terrace measurements indicate the ability of the stream to interact with its floodplain, if one is present.

Entrenchment ratio. The entrenchment ratio is defined as the floodprone width divided by the active channel width. Larger entrenchment ratios indicate greater interaction between the stream and its floodplain.

Stream flow type. Stream flow type codes are shown in the following table:

TYPE	DESCRIPTION
DR	Dry.
PD	Puddled. A series of isolated pools connected by a surface trickle or subsurface flow.
LF	Low flow. Surface water flowing across 50-75 % of the active channel.
MF	Moderate Flow. Surface water flowing across 75-90 % of the active channel.
HF	High flow. Stream flowing completely across active channel, but not at bankfull flow.
BF	Bankfull flow. Stream flowing at the upper level of the active channel margin.
FF	Flood flow. Stream flowing over banks onto terraces or floodplain. Flow above floodprone height if the channel is deeply incised.

Average unit gradient. The average unit gradient represents the overall steepness of the stream channel within each habitat unit throughout the reach.

Water temperature. The water temperature designation represents the measured temperatures on the day and time of the survey.

Habitat units/100m. The average number of habitat units per 100 meters represents the degree of fragmentation of the stream channel into different habitat types. Larger or less complex streams tend to have fewer units, while smaller or more complex streams tend to have greater numbers of units per 100 meters.

## How channel characteristics and dimensions are determined:

The survey crew measures or estimates and calibrates the length and width of each habitat unit. Overall reach lengths are compared against USGS topographic maps. Finally, lengths and areas are calculated and summed.

The widths and heights of the active channel, floodprone areas, and first terraces are all measured by the survey crew with a measuring tape. These measurements are known collectively as the **channel metrics**. The width to depth ratio, average unit gradient, and habitat units per 100 meters are derived during data analysis. Water temperature and relative stream flow are determined directly by the survey crew.

- **Significance for fish habitat:**

Primary and secondary channels. Lengths and areas of primary and secondary channels indicate the extent of potential fish habitat. Secondary channel lengths and areas indicate the amount of off-channel habitat potentially available to fish during high winter flows. The numbers of dry units provide clues to flow conditions at the time of the survey and may indicate the effects of water withdrawals or diversions.

Wetted width and depth. The average wetted width and depth indicate the size of the stream. In general, stream channels with significant depth compared to width have a higher potential for productive fish habitat.

Active channel width and height. Comparisons of the widths and heights of the active channel and floodprone areas describe the ability of the stream to move laterally during high flow events. The active channel height and width measurements indicate the extent of flow during normal high winter flows.

Width to depth ratio. Shade from riparian vegetation, cover from undercut banks, and water temperatures in pools are all affected by the width to depth ratio. A high width to depth ratio increases the water's exposure to solar radiation, resulting in potentially higher temperatures. Undercut banks are often reduced, affecting critical cover preferred by many salmonids.

Floodprone width and height. Floodprone height is defined as two times the active channel height. A measurement across the valley floor at this height determines the lateral extent of a 50 year flood event. It also indicates whether potential fish habitat in secondary channels could be accessed or affected by flood flows.

First terrace width and height. If the floodprone height is greater than the terrace height, terraces may be inundated by water during a 50-year flood event. If flood flows can interact with the floodplain, the stream channel has a lower potential for entrenchment. Over time, entrenchment decreases the ability of the stream to interact with its floodplain.

Entrenchment ratio. The entrenchment ratio indicates the potential for the stream to interact with its floodplain. Values greater than 1.0 signify increasing floodplain interaction, which encourages development of secondary channels. Floodplain interaction may enhance stands of riparian vegetation, improve streambank stability, and increase habitat complexity.

Stream flow type. Stream flow types are affected by the amount of base flow, and in some areas, snowpack. Many headwater areas simply dry up in late summer, eliminating any use by fish at that time.

Water temperature. Water temperature is one of the most critical aspects of fish habitat. Salmonids become stressed above 18° C, and the incipient lethal temperature for many salmonids occurs around 24° C (75° F).

Average unit gradient. The average unit gradient affects the types of habitat that can form, and the ability of various species to colonize those areas during variable seasonal flows.

Habitat units/100m. The average number of habitat units per 100 meters indicates the potential for different habitat unit types. Streams with more complex habitats have more units per 100 meters. Variety and complexity are hallmarks of good fish habitat.

### 3.0 RIPARIAN, BANK AND WOOD SUMMARY

A *Riparian, Bank and Wood Summary* is prepared for each reach. This summary provides a tabular synopsis of land use within the reach, riparian vegetation and its contribution to stream shade, the status of bank erosion and undercutting, and the distribution of pieces, volume, and key pieces of large woody debris.

#### 3.1 Land Use and Riparian Vegetation Codes

- What it means:

**Land use describes the landscape environment.**

**6** Land use. Codes for land uses within the reach are included in the report. Land use describes activities beyond the riparian area, on the hillslopes, and throughout the watershed in general. Land use and riparian vegetation codes are subdivided into primary land use or dominant vegetation, and secondary use or age class of vegetation.

**6**

Riparian, Bank, and Wood Summary			
	<u>Primary</u>	<u>Secondary</u>	
Land Use:	LT	MT	<b>7</b>
Riparian Vegetation:	D30	S	

Land use codes are shown in the following table:

USE	DESCRIPTION	USE	DESCRIPTION
<b>AG</b>	Agricultural	<b>LG</b>	Light Grazing
<b>TH</b>	Timber Harvest (active)	<b>HG</b>	Heavy Grazing
<b>YT</b>	Young Trees (up to 15 cm dbh)	<b>EX</b>	Exclosure
<b>ST</b>	Second Growth Timber (15-30 cm dbh)	<b>GN</b>	Greenway, park
<b>LT</b>	Large Timber (30-50 cm dbh)	<b>UR</b>	Urban
<b>MT</b>	Mature Timber (50-90 cm dbh)	<b>RR</b>	Rural Residential
<b>OG</b>	Old Growth (90+ cm dbh)	<b>IN</b>	Industrial
<b>PT</b>	Partial Timber (partial or thinned cut)	<b>MI</b>	Mining
<b>FF</b>	Forest Fire (recent)	<b>WL</b>	Wetland
<b>BK</b>	Bug Kill (Eastside with >60% mortality)	<b>NU</b>	No Use Identified
		<b>WA</b>	Designated Wilderness Area

**Riparian vegetation provides bank stability, shade over the channel, and large woody debris for recruitment into the stream.**

**7** Riparian vegetation. The riparian vegetation summary characterizes the vegetation within one active channel width on either side of the channel throughout the reach. Riparian vegetation is described with a two-part code. The first letter describes the type of vegetation, while the second refers to the age of trees and shrubs in the riparian area.

- How land use and riparian vegetation are determined:

The survey crew determines land use and riparian vegetation by visually assessing the hillslopes and riparian zone as they conduct the survey. Conversations with landowners also help determine land uses.

Riparian vegetation codes are shown in the following table:

VEGETATION TYPE	DESCRIPTION	SIZE CLASS (D, M, C types only)	DESCRIPTION
<b>N</b>	No vegetation	<b>1</b>	1-3 cm dbh. Seedlings & new plantings
<b>B</b>	Sagebrush	<b>3</b>	3-15 cm dbh. Young trees or saplings.
<b>G</b>	Annual grasses & forbs	<b>15</b>	15-30 cm dbh. Typical second growth.
<b>P</b>	Perennial grasses	<b>30</b>	30-50 cm dbh. Large, established trees.
<b>S</b>	Shrubs and vines	<b>50</b>	50-90 cm dbh. Mature, established trees with understory.
<b>D</b>	Deciduous dominated	<b>90</b>	90+ cm dbh. "Late successional", multi-layered canopy
<b>M</b>	Mixed coniferous/deciduous		
<b>C</b>	Coniferous dominated		

- **Significance for fish habitat:**

Riparian vegetation is a key component of fish habitat. A healthy riparian canopy shades the stream channel, in many cases preventing or reducing high summer water temperatures. Healthy riparian vegetation stabilizes stream banks with the reinforcing action of interconnecting root systems. Stabilized stream banks are more likely to develop bank **undercut**, which provides important cover for fish. Stabilized stream banks are less likely to provide fine sediments, which can embed spawning gravels and, in extreme cases, fill in pools. Riparian trees also provide the majority of large woody debris (LWD) recruitment into the stream.

### 3.2 Bank Condition and Shade

***Actively eroding banks are sources of silt and sand inputs into a stream. Reduced soil stability may also destabilize riparian vegetation.***

***Undercut banks can provide excellent cover for fish to rest or escape from predators.***

- **What it means:**

Bank condition (status) is the percent of the reach length with either actively eroding banks or undercut banks.

**8** Actively eroding. Material is removed by the action of flowing water on actively eroding banks. Actively eroding banks are usually composed of fine sediments and are not stabilized by vegetation. Actively eroding banks may contribute material slowly to the stream or collapse in large chunks under the force of gravity.

Bank Condition and Shade		
<u>Bank Status</u>	<u>Percent Reach Length</u>	<u>Shade (% of 180)</u>
Actively Eroding	8%	Reach avg: 89%
Undercut Banks	4%	Range: 62-100

Undercut banks. When the wetted channel has cut underneath a vegetatively stabilized bank, an undercut bank is formed. The horizontal surface of the bank overhangs the water. The lateral extent of the undercut may be a few centimeters up to a few meters.

**9** Shade. Shade is stated as a percentage of the 180-degree arc over the stream that is shaded by either topographic features or vegetation. The average shading, as well as the range of values, is given for the reach.

- **How bank condition and shade are determined:**

The survey crew visually determines the extent of actively eroding and undercut banks in each habitat unit as they move upstream. Each bank, left and right, is apportioned 50 percent of the total. For example, if the entire length of each bank within a habitat unit was undercut, the value would be 100%. If one bank was entirely undercut, but the other bank had no undercut, the value would be 50%, and so on. The percent reach length of both actively eroding and undercut banks is determined during data analysis.

Stream shade measurements are described in Section 6.1, Percent Shade. The average percent shade and the range of values for the reach are determined during data analysis.

- **Significance for fish habitat:**

Although bank erosion is a natural process, actively eroding banks are significant sources of silt and sand. The effects of fine sediments upon substrate embeddedness are described in Section 6.2, Percent of Substrate Silt, Organics and Sand. Actively eroding banks tend to inhibit the development of undercut banks, which provide desirable habitat for salmonids. Unstable, actively eroding banks also degrade riparian vegetation.

Salmonids strongly prefer the habitat provided by undercut banks. Flow velocities are lower beneath undercut banks, creating ideal holding areas and cover from predators.

### 3.3 Large Woody Debris Summary

- **What it means:**

**10** Large woody debris is displayed in total pieces and as the number of pieces per 100 meters of stream channel per reach.

10



Large Woody Debris		
	<u>Total</u>	<u>Total/100m</u>
All pieces (≥3m x 0.15m)	99	8.5
Volume (m <sup>3</sup> )	76	6.5
Key pieces (≥10m x 0.6m)	1	0.1

- **How a large woody debris summary is determined:**

Measurement and counting of large woody debris and key pieces of wood are described in Section 6.7, Pieces and Volume of Large Wood, and Section 6.8, Key Pieces of Large Wood.

- **Significance for fish habitat:**

The significance of large woody debris and key pieces of wood in fish habitat are described in Section 6.7, Pieces and Volume of Large Wood, and Section 6.8, Key Pieces of Large Wood.



Large woody debris and key pieces of wood provided by willow, cottonwood, juniper, and even aspen at higher elevations, are also important components of fish habitat in desert streams.

# HABITAT UNIT REPORT

(Page 1 of 2)

OREGON DEPT. FISH AND WILDLIFE  
HABITAT INVENTORY Report Date: 05/04/99

GREEN CREEK #956  
Survey Date: 06/23/98

## HABITAT UNIT SUMMARY

11

(p. 17)

**REACH 1** **T17S-R9W-16NE** **REACH 1**

### HABITAT DETAIL

Habitat Type	Number Units	Total Length (m)	Avg Width (m)	Avg Depth (m)	Total Area (m <sup>2</sup> )	Large Boulders (>0.5m)	Substrate Percent Wetted Area					
							S/O	Snd	Grvl	Cbbl	Bldr	Bdrk
DRY UNITS	1	6	3.5	0.00	21	0	6	11	44	22	0	17
GLIDE	11	210	6.6	0.27	1,341	38	9	15	17	9	2	48
POOL-LATERAL SCOUR	14	229	5.0	0.54	1,199	32	19	16	25	24	8	8
POOL-PLUNGE	2	27	10.6	0.60	295	5	31	15	10	3	3	39
POOL-STRAIGHT SCOUR	5	68	5.3	0.39	353	21	15	17	19	21	11	17
PUDDLED CHANNEL	1	8	3.0	0.07	24	5	6	6	31	50	6	0
RAPID/BEDROCK	2	32	8.1	0.10	266	0	0	13	8	0	0	80
RAPID/BOULDERS	1	5	1.7	0.25	9	3	5	10	10	15	55	5
RIFFLE	19	583	5.6	0.13	3,448	180	3	10	22	20	5	41
RIFFLE W/ POCKETS	1	27	6.5	0.20	178	7	5	10	10	5	5	65
STEP/BEDROCK	4	3	8.5	0.06	14	2	0	0	0	1	1	98
STEP/COBBLE	2	7	4.4	0.09	30	8	0	8	36	48	6	3
STEP/LOG	1	0	13.7	0.05	3	0	16	26	26	32	0	0
<b>Total:</b>	<b>64</b>	<b>1,206</b>	<b>6.0</b>	<b>0.27</b>	<b>7,178</b>	<b>301</b>	<b>Avg: 9</b>	<b>12</b>	<b>20</b>	<b>18</b>	<b>6</b>	<b>35</b>

### HABITAT SUMMARY

12

(p. 18)

Habitat Group	No. Units	Total Length (m)	Avg Width (m)	Avg Depth (m)	Wetted Area (m <sup>2</sup> ) Percent		Large Boulders Number	Boulders #/100m <sup>2</sup>
Dammed & BW Pools	0	0	-	-	0	0.00	0	0.0
Scour Pools	21	325	5.6	0.51	1,846	25.72	58	3.1
Glides	11	210	6.6	0.27	1,341	18.68	38	2.8
Riffles	20	611	5.7	0.14	3,625	50.50	187	5.2
Rapids	3	38	5.9	0.15	275	3.82	3	1.1
Cascades	0	0	-	-	0	0.00	0	0.0
Step/Falls	7	10	8.1	0.06	47	0.66	10	21.2
Dry	2	14	3.3	0.04	45	0.62	5	11.2

### POOL SUMMARY

13

(p. 19)

All Pools	<u>Total</u>	<u>#/Km</u>
	21	17.4
Pools ≥1m deep:	1	0.8
Complex pools (LWD pieces ≥3):	3	2.5
Pool Frequency (channel widths/pool):	5.3	
Residual pool depth (avg)	0.34m	

**STREAM SUMMARY**

**GREEN CREEK #956**

Number Units	Total Length (m)	Avg Width (m)	Avg Depth (m)	Total Area (m <sup>2</sup> )	S/O	Substrate					Total Large Boulder
						Percent Sand	Grvl	Wetted Area Cbbl	Bldr	Bdrk	
64	1,206	6.0	0.27	7,178	9	12	20	18	6	35	301

(p. 19)

**14**



Habitat Group	Wetted Area	
	(m <sup>2</sup> )	Percent
Scour Pool	1,846	25.7
Backwater Pools	0	0.0
Glide	1,341	18.7
Riffle	3,625	50.5
Rapid	275	3.8
Cascade	0	0.0
Step	47	0.7
Dry	45	0.6

## Habitat Unit Report

### 4.0 HABITAT UNIT SUMMARY

*The habitat unit report summarizes information that most directly relates to the fish community. A discussion of instream habitat requires an examination of the sequence and features of habitat units in each reach.*

A *Habitat Unit Summary* is prepared for each reach. It describes the mix of habitat types, average dimensions of the habitat units, and the amounts of substrate types and large boulders. A detailed description of several important features is presented in Section 6.0, Stream Profile Graphs.

11

HABITAT DETAIL												
Habitat Type	Number Units	Total Length (m)	Avg Width (m)	Avg Depth (m)	Total Area (m <sup>2</sup> )	Large Boulders (#>0.5m)	Substrate					
							Percent Wetted Area					
							S/O	Snd	Grvl	Cbbl	Bldr	Bdrk
DRY UNITS	1	6	3.5	0.00	21	0	6	11	44	22	0	17
GLIDE	11	210	6.6	0.27	1,341	38	9	15	17	9	2	48
POOL-LATERAL SCOUR	14	229	5.0	0.54	1,199	32	19	16	25	24	8	8
POOL-PLUNGE	2	27	10.6	0.60	295	5	31	15	10	3	3	39
POOL-STRAIGHT SCOUR	5	68	5.3	0.39	353	21	15	17	19	21	11	17
PUDDLED CHANNEL	1	8	3.0	0.07	24	5	6	6	31	50	6	0
RAPID/BEDROCK	2	32	8.1	0.10	266	0	0	13	8	0	0	80
RAPID/BOULDERS	1	5	1.7	0.25	9	3	5	10	10	15	55	5
RIFFLE	19	583	5.6	0.13	3,448	180	3	10	22	20	5	41
RIFFLE W/ POCKETS	1	27	6.5	0.20	178	7	5	10	10	5	5	65
STEP/BEDROCK	4	3	8.5	0.06	14	2	0	0	0	1	1	98
STEP/COBBLE	2	7	4.4	0.09	30	8	0	8	36	48	6	3
STEP/LOG	1	0	13.7	0.05	3	0	16	26	26	32	0	0
<b>Total:</b>	<b>64</b>	<b>1,206</b>	<b>6.0</b>	<b>0.27</b>	<b>7,178</b>	<b>301</b>	<b>Avg: 9</b>	<b>12</b>	<b>20</b>	<b>18</b>	<b>6</b>	<b>35</b>

#### 4.1 Habitat Detail

- **What it means:**

**11** The report describes the types and character of habitat units observed by the survey crew. The number of each unit type, total length, average width and depth, and total area are presented. The Habitat Detail section also describes the number of large boulders counted and the substrate composition of each unit type.

- **How habitat detail is determined:**

Habitat types are described according to the slope of the water's surface, flow characteristics, and substrate. Refer to the Methods Manual for more detail. Large boulders are those which have a diameter of 0.5 m or greater, and protrude from the water surface. Substrate types are visually estimated for each unit and large boulders are counted.

- **Significance for fish habitat:**

The number of different habitat units indicates the complexity of the reach. For example, backwater pools, alcoves, and dammed and beaver pools provide refuge habitat for fish during high flows. Depth of the units indicates the flow at the time of the survey and the potential for high quality fish habitat. Depth in both pool and fast water habitat is important for juvenile and adult fish. Each unit's substrate composition provides information about stream roughness and hydrologic complexity. Substrate also influences survival of salmonids at different life stages. High percentages of silt and sand in riffle areas may indicate poor quality spawning habitat, while cobbles and boulders in pools are important winter rearing habitat.

12

HABITAT SUMMARY								
Habitat Group	No. Units	Total Length (m)	Avg Width (m)	Avg Depth (m)	Wetted Area (m <sup>2</sup> )	Wetted Area Percent	Large Boulders Number	Boulders #/100m <sup>2</sup>
Dammed & BW Pools	0	0	-	-	0	0.00	0	0.0
Scour Pools	21	325	5.6	0.51	1,846	25.72	58	3.1
Glides	11	210	6.6	0.27	1,341	18.68	38	2.8
Riffles	20	611	5.7	0.14	3,625	50.50	187	5.2
Rapids	3	38	5.9	0.15	275	3.82	3	1.1
Cascades	0	0	-	-	0	0.00	0	0.0
Step/Falls	7	10	8.1	0.06	47	0.66	10	21.2
Dry	2	14	3.3	0.04	45	0.62	5	11.2

#### 4.2 Habitat Summary

- **What it means:**

12

The Habitat Summary section groups habitat units into general categories. Beaver pools, dammed pools, alcoves, backwaters, and isolated pools are grouped into “Dammed & BW Pools”; lateral scour, straight scour, trench pools, and plunge pools into “Scour Pools”; riffles and riffles with pockets into “Riffles”; rapids over boulders and rapids over bedrock into “Rapids”; cascades over boulders and cascades over bedrock into “Cascades”; and all step unit types into “Step/Falls”. Dry channels, puddled channels, and dry units are grouped into “Dry.” Average dimensions, wetted area, and percent of wetted area are presented. The number of large boulders in each unit type is calculated on a “per 100 meters” average. Note that the rapids, cascades, and steps usually have the largest number of boulders.

- **How a habitat summary is determined:**

Survey methods are explained in previous sections. The Habitat Summary section is a calculated summary of the Habitat Detail section.

- **Significance for fish habitat:**

Significance for fish habitat is explained in the previous section, Habitat Detail. Information from the Habitat Summary section is used to create Habitat Bar Graphs (see Section 7).

### 4.3 Pool Summary

- **What it means:**

**13** The number and depth of pools is a measure of the pool habitat in the stream at the time of the survey. The *Pool Summary* characterizes the pool habitat in terms of total number of pools, pools deeper than 1 meter, pools associated with at least 3 pieces of large woody debris, and the frequency or spacing of pools. The summary also standardizes the number of pools by calculating the average number of pools per kilometer of stream.

- **How a pool summary is determined:**

The summary is a calculation based on the number and depth of pools in the reach. Complex pools are those pools with at least three pieces of associated wood. Residual pool depth (avg) is the maximum pool depth less the depth at the pool tail crest, averaged for the pools of the reach. Pool frequency (channel widths/pool) is the number of active channel widths between pools. It is a measure of the frequency of occurrence of pools in a reach relative to the size of the stream.

- **Significance for fish habitat:**

Pools, particularly deep pools, are important habitat for juvenile and adult fish. Pools provide slow water habitat, critical over-wintering habitat for some species and sometimes, the only habitat available for fish during the summer low flow period. Pools with depth and/or large wood are particularly desirable for increased space and complexity. The importance of deep pools is further discussed in Section 6.6, Number of Deep Pools.

### 4.4 Stream Summary

- **What it means:**

**14** The *Stream Summary* portion of the *Habitat Unit Report* summarizes the habitat unit type and substrate character for the whole stream.

- **How a stream summary is determined:**

The values are calculated from the unit information obtained in all surveyed reaches.

- **Significance for fish habitat:**

The *Stream Summary* section provides a cursory description of the habitat across all reaches of the stream. The mix of habitat units and substrate indicates the habitat character and its suitability for different aquatic species.

STREAM SUMMARY				GREEN CREEK #956							
Number Units	Total Length (m)	Avg Width (m)	Avg Depth (m)	Total Area (m <sup>2</sup> )	S/O	Substrate Percent Wetted Area					Total Large Boulder
						Sand	Grvl	Cbbl	Bldr	Bdrk	
64	1,206	6.0	0.27	7,178	9	12	20	18	6	35	301
				Wetted Area (m <sup>2</sup> )							
				Habitat Group	Wetted Area (m <sup>2</sup> )		Percent				
				Scour Pool	1,846	25.7					
				Backwater Pools	0	0.0					
				Glide	1,341	18.7					
				Riffle	3,625	50.5					
				Rapid	275	3.8					
				Cascade	0	0.0					
				Step	47	0.7					
				Dry	45	0.6					

# RIPARIAN ZONE REPORT

(Page 1 of 2)

**15** (p. 22)

OREGON DEPARTMENT OF FISH AND WILDLIFE  
HABITAT INVENTORY Report Date: 12/28/98

CLEAR CREEK (N225)  
Survey Date: 08/05/98

REACH 1 RIPARIAN ZONE VEGETATION SUMMARY REACH 1

## Summary of Riparian Zone (0-30m) (3 transects)

Total hardwoods/1000 ft 122  
Total conifers/1000 ft 61  
Total conifers >20" dbh/1000 ft 20  
Total conifers >35" dbh/1000 ft 0

## Average number of trees in a 5-meter wide band

Diameter class (cm)	Zone 1 0-10 meters		Zone 2 10-20 meters		Zone 3 20-30 meters		Zones 1-3 0-30 meters	
	Conifer	Hardwood	Conifer	Hardwood	Conifer	Hardwood	Conifer	Hardwood
3-15cm	0.0	0.3	0.0	0.7	0.0	0.3	0.0	1.3
15-30cm	0.0	0.0	0.0	0.3	0.0	0.3	0.0	0.7
30-50cm	0.3	0.0	0.0	0.0	0.3	0.0	0.7	0.0
50-90cm	0.3	0.0	0.0	0.0	0.0	0.0	0.3	0.0
>90cm	0.0	0.0	0.0	0.0	0.0	0.0	0.0	0.0
Total/100m <sup>2</sup>	0.7	0.3	0.0	1.0	0.3	0.7	0.3	0.7

## Canopy closure and ground cover

	Zone 1 0-10 meters		Zone 2 10-20 meters		Zone 3 20-30 meters	
	(%)		(%)		(%)	
Canopy closure	7		8		12	
Shrub cover	78		98		100	
Grass/forb cover	20		2		0	

## Predominant landform in each zone

	Zone 1 0-10 meters		Zone 2 10-20 meters		Zone 3 20-30 meters	
	Hillslope	83		100		100
High terrace	0		0		0	
Low terrace	17		0		0	
Floodplain	0		0		0	
Wetland/meadow	0		0		0	
Stream channel	0		0		0	
Roadbed/Railroad	0		0		0	
Riprap	0		0		0	
Surface slope (%)	98		107		107	

**16**

(p. 23)

# RIPARIAN ZONE REPORT

## (Page 2)

OREGON DEPARTMENT OF FISH AND WILDLIFE  
HABITAT INVENTORY - RIPARIAN SURVEY

CLEAR CREEK (N225)  
08/05/98

---

Summary of Riparian Zone (0-30m) for all reaches ( 3 transects)

Summary of riparian zone (0-100ft) extrapolated to 1,000 feet along stream

Total hardwoods/1000 ft	122
Total conifers/1000 ft	61
Total conifers >20" dbh/1000 ft	20

Average number of trees in a 5-meter wide band

Diameter <u>class (cm)</u>	Zones 1-3	
	<u>Conifer</u>	<u>Hardwood</u>
3-15cm	0.0	1.3
15-30cm	0.0	0.7
30-50cm	0.7	0.0
50-90cm	0.3	0.0
>90cm	0.0	0.0



# Riparian Zone Report

## 5.0 RIPARIAN ZONE SUMMARY

***Riparian zone vegetation is the plant community adjacent to the stream channel. Riparian vegetation is important for providing stream shade, stabilizing stream banks, and providing large woody debris to the stream channel.***

A *Riparian Zone Vegetation Summary* is prepared for each reach and provides detail about the species composition, abundance and size distribution of riparian zone vegetation. This information correlates with the quality of fish habitat described in other portions of the report. It summarizes the mix and sizes of general vegetation categories found in the riparian zone, calculates the average number of trees in the five-meter wide transects, and evaluates the canopy closure and ground cover with respect to predominant landforms in the riparian zone. The various vegetation categories are then extrapolated to amounts per 1000 feet of stream.

### 5.1 Riparian Zone Vegetation Summary

- **What it means:**

15

The *Riparian Zone Vegetation Summary* report describes the average conditions in the 30 meter by 5 meter transects adjacent to each side of the stream channel. It describes the number, type, and diameter of trees in three zones, each 10 meters long, extending perpendicular to the stream. It also describes the predominant landform in each zone, the slope, canopy density, and shrub and grass cover. The number of trees is expressed as the number of total trees, number of conifer trees larger than 20 inch dbh (diameter at breast height), and number of trees larger than 36 inch dbh in a 1,000 foot zone parallel to the stream, extending 100 feet (30 meters) on each side of the stream.

- **How a riparian zone vegetation summary is determined:**

Riparian transects are sampled at least once per reach, and are conducted at regular intervals as the survey proceeds. Each transect extends 30 meters perpendicular to the stream and is broken into 3 blocks, each 10 meters by 5 meters wide. Crews estimate the shrub and grass cover, and canopy density. The number of trees  $\geq 3$ cm diameter and  $\geq 2.5$ m high is counted and the sizes of trees are estimated.

- **Significance for fish habitat:**

Riparian zones provide a wide range of functions important to the maintenance of high quality fish habitat. Riparian zones are the major source of recruitment for large woody debris in the channel. The trees in the riparian area also help anchor trees that fall into the stream. The canopy provides shade to maintain lower stream temperatures. The vegetation stabilizes the banks, provides habitat for terrestrial invertebrates that serve as food for salmonids, and provides nutrients and detritus to the stream. The riparian zone serves as a buffer between terrestrial and aquatic ecosystems, influencing the rate and type of materials transported to the stream system.

## 5.2 Canopy closure, ground cover, and predominant landform in each zone

- **What it means:**

**16** The canopy closure, ground cover, and predominant landforms sections summarize additional aspects of the 30m by 5m riparian transects. Canopy closure refers to the extent that the canopy shades the ground within each zone. Ground cover represents the percentage of the ground in each zone, which is covered by shrubs, grasses, forbs, or ferns. The predominant landform describes the geomorphic feature(s) as well as the slope of the dominant feature.

Canopy closure and ground cover			
	Zone 1	Zone 2	Zone 3
	0-10 meters	10-20 meters	20-30 meters
	(%)	(%)	(%)
Canopy closure	7	8	12
Shrub cover	78	98	100
Grass/forb cover	20	2	0

Predominant landform in each zone			
	Zone 1	Zone 2	Zone 3
	0-10 meters	10-20 meters	20-30 meters
Hillslope	83	100	100
High terrace	0	0	0
Low terrace	17	0	0
Floodplain	0	0	0
Wetland/meadow	0	0	0
Stream channel	0	0	0
Roadbed/Railroad	0	0	0
Riprap	0	0	0
Surface slope (%)	98	107	107

**16**

- **How it is determined:**

Canopy closure percentages and ground cover distributions are estimated by the crew visually within each 10m long zone of each transect. The predominant landform in each zone is identified visually. The surface slope of each zone is measured with a clinometer.

- **Significance for fish habitat:**

The riparian zone serves as a buffer between the terrestrial and aquatic ecosystems. The canopy closure, ground cover, and landforms within the riparian zone influence both the rate of flux, and the types of materials, which are transported into the aquatic system.

# RIPARIAN ZONE VEGETATION DETAIL REPORT

OREGON DEPARTMENT OF FISH AND WILDLIFE  
 HABITAT INVENTORY Report Date: 12/28/98

CLEAR CREEK (N225)  
 Survey Date: 08/05/98

RIPARIAN ZONE VEGETATION

17

Reach 1

Reach 1

VEGETATION DETAIL

(p. 25)

Unit	Side	Zone	Surface	Slope	Cover (percent)				Diameter class (cm)					Notes
					Canopy	Shrub	Grass		3-15	15-30	30-50	50-90	>90	
10	LF	1	HS	120.0	0	90	10	Conifer	0	0	0	0	0	
								Hardwood	0	0	0	0	0	NO TREES
10	LF	2	HS	120.0	0	100	0	Conifer	0	0	0	0	0	
								Hardwood	0	0	0	0	0	NO TREES
10	LF	3	HS	120.0	10	100	0	Conifer	0	0	0	0	0	
								Hardwood	0	0	0	0	0	NO TREES
10	RT	1	HS	150.0	0	90	10	Conifer	0	0	0	0	0	
								Hardwood	0	0	0	0	0	
10	RT	2	HS	120.0	10	100	0	Conifer	0	0	0	0	0	
								Hardwood	0	1	0	0	0	
10	RT	3	HS	120.0	20	100	0	Conifer	0	0	0	0	0	
								Hardwood	0	1	0	0	0	
36	LF	1	HS	90.0	0	100	0	Conifer	0	0	0	0	0	
								Hardwood	1	0	0	0	0	MAPLE
36	LF	2	HS	90.0	10	100	0	Conifer	0	0	0	0	0	
								Hardwood	0	0	0	0	0	
36	LF	3	HS	90.0	0	100	0	Conifer	0	0	0	0	0	
								Hardwood	1	0	0	0	0	ALDER
36	RT	1	HS	110.0	40	80	10	Conifer	0	0	1	1	0	
								Hardwood	0	0	0	0	0	SITKA SPRUCE
36	RT	2	HS	90.0	10	90	10	Conifer	0	0	0	0	0	
								Hardwood	0	0	0	0	0	
36	RT	3	HS	90.0	20	100	0	Conifer	0	0	0	0	0	
								Hardwood	0	0	0	0	0	
57	LF	1	LT	0.0	0	10	90	Conifer	0	0	0	0	0	
								Hardwood	0	0	0	0	0	
57	LF	2	HS	100.0	0	100	0	Conifer	0	0	0	0	0	
								Hardwood	0	0	0	0	0	
57	LF	3	HS	100.0	20	100	0	Conifer	0	0	0	1	0	
								Hardwood	0	0	0	0	0	DOUGLAS FIR
57	RT	1	HS	120.0	0	100	0	Conifer	0	0	0	0	0	
								Hardwood	0	0	0	0	0	
57	RT	2	HS	120.0	20	100	0	Conifer	0	0	0	0	0	
								Hardwood	2	0	0	0	0	ALDER
57	RT	3	HS	120.0	0	100	0	Conifer	0	0	0	0	0	
								Hardwood	0	0	0	0	0	

### 5.3 Riparian Zone Vegetation Detail

- **What it means:**

**17** The *Vegetation Detail* report describes the characteristics of each riparian transect. It lists the size and number of hardwood and conifer trees counted, the geomorphic surface (predominant landform), shrub and grass cover, as well as slope and canopy density. The “Notes” column may also list the dominant tree species. The survey crew documents the location of each transect on a 7.5 minute topographic map.

- **How riparian zone vegetation detail is determined:**

The information is estimated or measured by the survey crew in each of three 5 meter by 10 meter subsections within each transect. A transect is surveyed on each side of the stream at a minimum of every 30 units or 1 kilometer, whichever is shorter.

- **Significance for fish habitat:**

The riparian zone provides important material to and buffering for the stream. The detail report shows the characteristics of each subsection of each transect.

## 6.0 STREAM PROFILE GRAPHS

**A stream profile graph represents a picture of the stream gradient along its surveyed length. Profiles provide clues to the types and characteristics of habitat expected along the stream's length.**

- **What it means:**

Stream **profile** graphs depict a stream channel's change in elevation (above mean sea level) over the surveyed distance of the stream, producing a continuous picture of the stream **gradient**. On the graphs, the ratio of elevation to distance is generally 1:20, allowing reasonable comparisons of gradients from various streams or stream reaches. Low gradient stream sections have a nearly horizontal profile, while higher gradient sections have a more vertical profile. If the graph axes represent a 1:20 ratio, a diagonal profile indicates a 5% slope.

Positions of significant stream channel features are layered upon the stream profile. Key features are listed below, but others may be added if required by survey objectives.

- ⇒ **Reach** breaks
- ⇒ Bridges, road crossings, culvert crossings
- ⇒ Tributary junctions
- ⇒ **Mass failures**
- ⇒ **Debris jams**

- **How stream profile graphs are created:**

Stream profile graphs are created from measurements obtained by the survey crew as they move upstream. The crew measures the length and water surface slope of each **habitat unit**. By stringing together the length and slope measurements in a chain during data analysis, the profile graphs are produced.

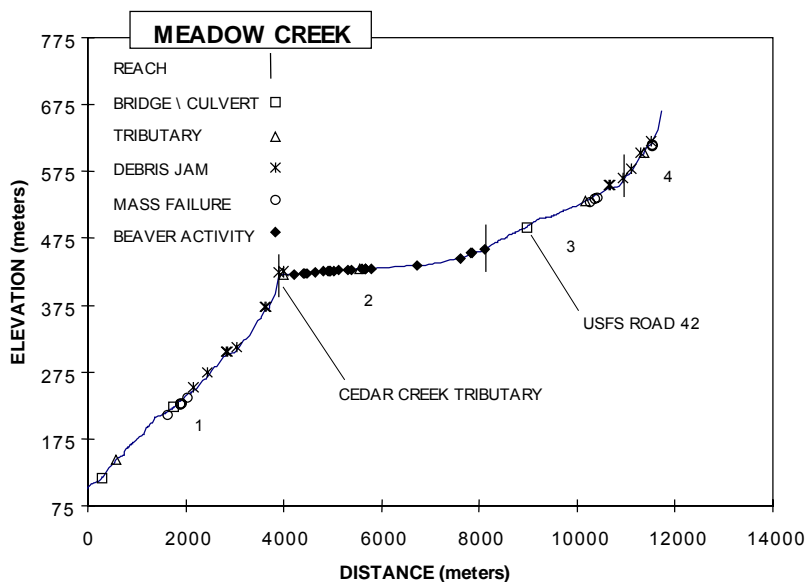

**Figure 1.** Stream profile graph. Note the four reaches in the survey. Note how the gradient decreases in Reach 2 and then increases in Reaches 3 and 4. Note the positions of tributaries and beaver activity.

- **Significance for fish habitat:**

Certain measurements obtained from the raw survey data are plotted on top of the stream profile. This produces a picture of how a habitat feature varies in relation to the gradient along the length of the stream. A scale assists the user with the quantitative value of each feature. The following list of key habitat parameters affect fish populations in stream habitats. These parameters are most often plotted on profile graphs. A detailed discussion of each follows.

- Percent **shade**
- Percent of **substrate** composed of **silt and organics**, and sand
- Percent of substrate composed of **gravel**
- Percent of substrate composed of **bedrock**
- **Large boulders** per 100 meters (running average)
- Depth of deep pools
- Number of pieces of **large wood**
- **Key pieces** of large wood

### 6.1 Percent Shade

*Percent shade describes the amount of vegetative or topographic cover to the stream channel. Shade helps maintain low water temperatures necessary for salmon and trout survival.*

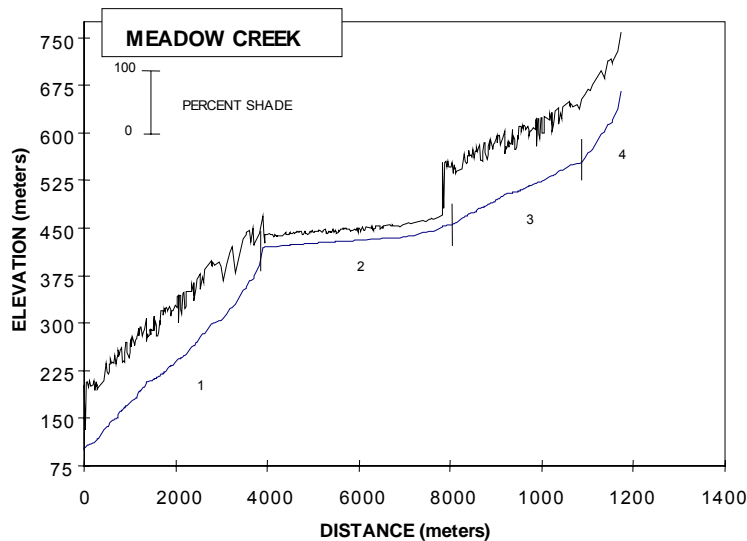

**Figure 2.** Percent shade plot. Areas with the highest shade percentage have the least channel exposure. Note how the shade decreases dramatically in Reach 2. This may be caused by the beaver activity in the reach (see Figure 1).

- **What it means:**

Percent shade is a measure of how much of the stream channel is shaded at the time of the survey.

- **How is percent shade determined:**

The survey crew uses a **clinometer** (an instrument that measures vertical angles) to find the angle from the center of the stream upward to the feature providing the shade on either side of the stream. Shade is provided by trees or other vegetation (vegetative shading), or by terraces, cliffs, or hillslopes adjacent to the stream (topographic shading). The angle measurements are made in each **habitat unit** during the survey. During data analysis, shade measurements are converted to percent shade for each habitat unit. Each percent shade measurement is subsequently plotted at its position along the stream profile graph to create a continuous picture of stream shading along the entire length of the survey.

- **Significance for fish habitat:**

Shade moderates instream water temperatures. This is especially true during the summer when air temperatures are high, flows are low, days are long, and the sun's high angle causes more radiant solar energy to strike the stream. Shading helps reduce overall stream temperatures and buffers daily water temperature fluctuations. High water temperatures limit fish production in watersheds, as well as upstream and downstream distribution of fish species. **Salmonids** as a group are especially sensitive to high water temperatures. Shade and streamside vegetation can also moderate temperature in the winter, preventing the formation of ice. The effect of stream shading upon water temperatures generally decreases as the stream widens and deepens.

## 6.2 Percent of Substrate Silt, Organics, and Sand

***Percent silt, organics and sand reflects the amount of silt, fine organic matter, and sand on the stream bottom. Silt, organic deposits, and sand are harmful if they cover or surround gravels used by salmon and trout for spawning; or prevent juvenile salmon from using the interstitial spaces between boulders, cobble, and gravel for cover.***

- **What it means:**

The percent of substrate composed of silt, organics, and sand is a measure of the amount of stream bottom, or substrate, composed of the smallest particle sizes. Although calculated separately during the survey, the amount of sand particles is included with silt and organics for the purposes of this graph. Diameters of these particles range from .062 to 2.0 millimeters. Silt, organics, and sand are often referred to collectively as "fine sediments" or "fines." Silt is easily held in suspension by flowing water, is easily dislodged from the stream bottom and banks, and clouds the water when disturbed. Fine particles of organic matter often occur with silt deposits and are grouped for purposes of the survey.

- **How is percent of substrate silt, organics, and sand determined:**

Survey crew members visually estimate the substrate amounts for each range of particle sizes. Substrate estimates are completed for each habitat unit surveyed.

- **Significance for fish habitat:**

Sand, silt and organic matter are natural components of stream systems. However, excessive amounts of these small particles contribute to the **embeddedness** of the substrate.

Embeddedness is defined as the degree to which larger particles, such as boulders, **cobble**, and gravel, are surrounded and/or covered by smaller particles. Excessive deposits of fine sediments severely restrict spawning habitat for salmonids by filling in the spaces between larger substrate particles. Newly spawned eggs often lodge in these spaces. Developing embryos and newly hatched **alevins** need these gaps between substrate particles for physical space and the delivery of well-oxygenated water (Everest, et al. 1987). Excessive deposits of fine sediments also reduce habitat for **macroinvertebrates**, such as aquatic insects, which are the primary food source for juvenile salmonids (Cummins and Klug, 1979). Silt deposits can even restrict juvenile **harborage** from high winter flows by filling in pools, especially **off-channel** pools. Because particles of silt and organic matter are easily transported by flowing water, sources of these particles, such as landslides, earthflows, or collapsing banks, can affect large areas of habitat downstream from the source.

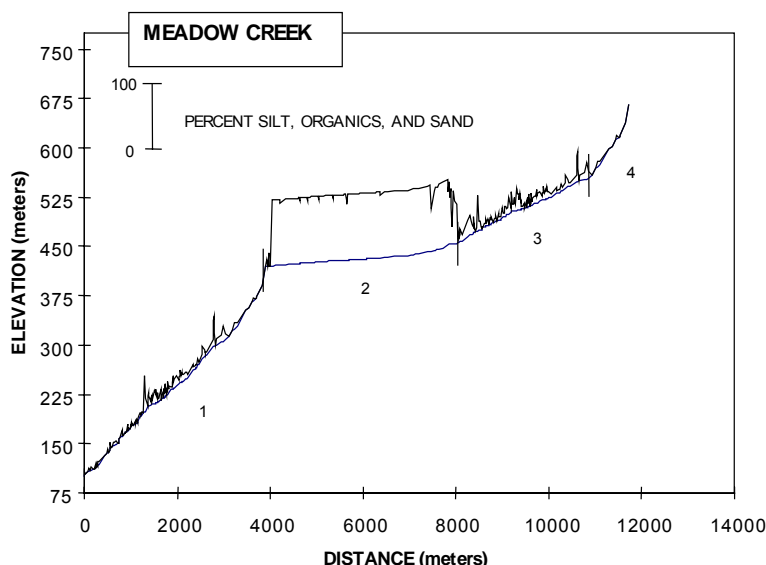

**Figure 3.** Silt, organics, and sand plot. Note the accumulation of fines in Reach 2 where there is extensive beaver activity and a decrease in gradient.

### 6.3 Percent Of Substrate Gravel

**Percent gravel describes the amount of gravel in the stream bottom. Trout and salmon use gravel areas for spawning. For developing young to survive, spawning gravels must be free of silt or sand. Different species of fish need different sizes of gravel to spawn successfully.**

- **What it means:**

The percent of substrate composed of gravel is a measure of the amount of the stream bottom, or substrate, composed of moderately sized particles. Gravel particles range in size from a small pea to roughly baseball-sized (diameters of 2 to 64 millimeters).

- **How is percent of substrate gravel determined:**

Survey crew members visually estimate the substrate amounts for each range of particle sizes. Substrate estimates are completed for each habitat unit surveyed.



- **Significance for fish habitat:**

All species of salmonids spawn in gravel. Each species prefers a different gravel size for spawning, thus multiple species may utilize the same area of stream habitat. For example, small resident cutthroat trout prefer small gravel sizes for spawning, while heavy, powerful chinook salmon prefer larger gravels and cobbles in which to construct their nesting sites, or **redds**. Redds are usually constructed in the downstream margins of pools, known as **tailouts**, and in riffle habitat. The availability of porous, silt-free spawning gravels affects the distribution and reproductive success of salmonids within the stream. Gravel particles absorb some of the energy of flowing water as they are transported downstream. The transport of gravels during various seasonal flows is a dynamic process that continually reshapes habitat within the stream.

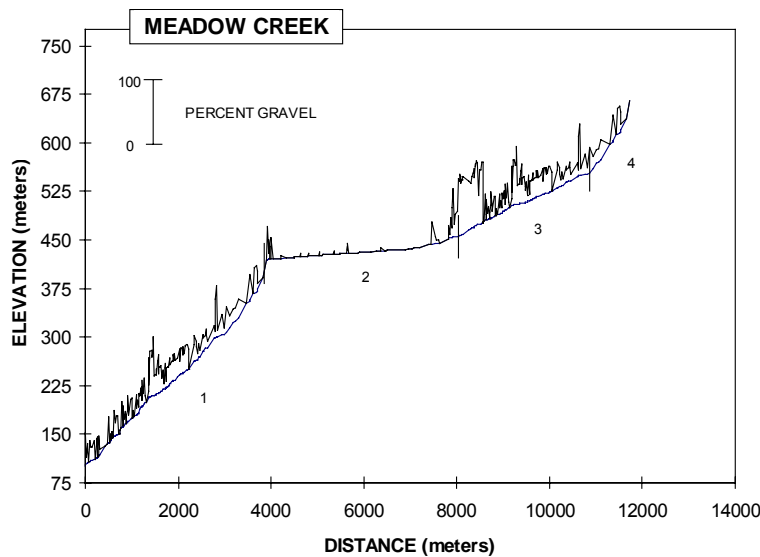

Figure 4. Percent gravel plot.

#### 6.4 Percent Of Substrate Bedrock

*Percent bedrock describes the amount of bedrock in the stream bottom. Bedrock substrates offer low friction against flowing water. Lower friction results in higher flow velocities in steep stream channels. Trench pools may also form in bedrock areas, and can offer deep water refugia for fish in the pool bottoms.*

- **What it means:**

The percent of substrate composed of bedrock is a measure of the amount of the stream bottom, or substrate, composed of **igneous** bedrock, such as basalt or rhyolite, **sedimentary** bedrock, such as sandstone, shale, or conglomerates, or **metamorphic** bedrock, such as slate or schist.

- **How is percent of substrate bedrock determined:**

Survey crew members visually estimate the substrate amounts for each range of particle sizes. Substrate estimates are completed for each habitat unit surveyed.

- **Significance for fish habitat:**

Bedrock substrates offer little resistance to the energy of water flowing downstream. The lower friction over bedrock results in higher flow velocities, especially in steeper areas. Areas of high velocity flows do not offer resting areas for fish, especially for juvenile salmonids, as they must expend too much energy to avoid being washed downstream by the flow.

Some areas in very narrow valleys with predominantly bedrock substrate can form **trench pools**. Trench pools can be quite deep. The bottom of the pool provides deep water refugia for fish.

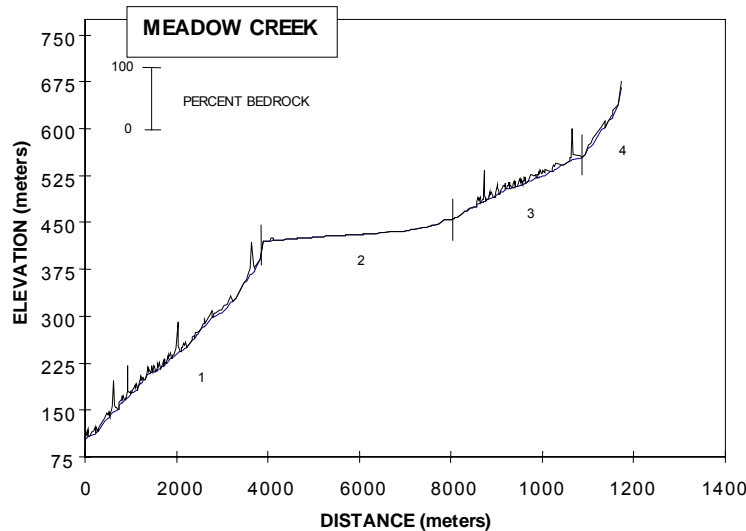

**Figure 5.** Percent bedrock plot. Note the increasing amounts of bedrock in the higher gradient reaches.

## 6.5 Large Boulders Per 100 Meters

***Large boulders per 100 meters refer to the density of boulders with diameters of at least 0.5 meter protruding from the water surface. These boulders provide roughness to the stream channel. Large boulders also create habitat that provides resting and feeding areas for fish.***

- **What it means:**

Large boulders per 100 meters (running average) refers to a count of large boulders 0.5 meter in diameter or larger that exist as part of the stream substrate and that protrude above the surface of the water at the time of the survey. Because completely submerged boulders are not counted, the density of boulders provides a relative measure, rather than an exact count.

- **How is the running average for large boulders per 100 meters determined:**

The survey crew counts all large boulders meeting the minimum size and position criteria in each habitat unit. The running average is determined during the data analysis.

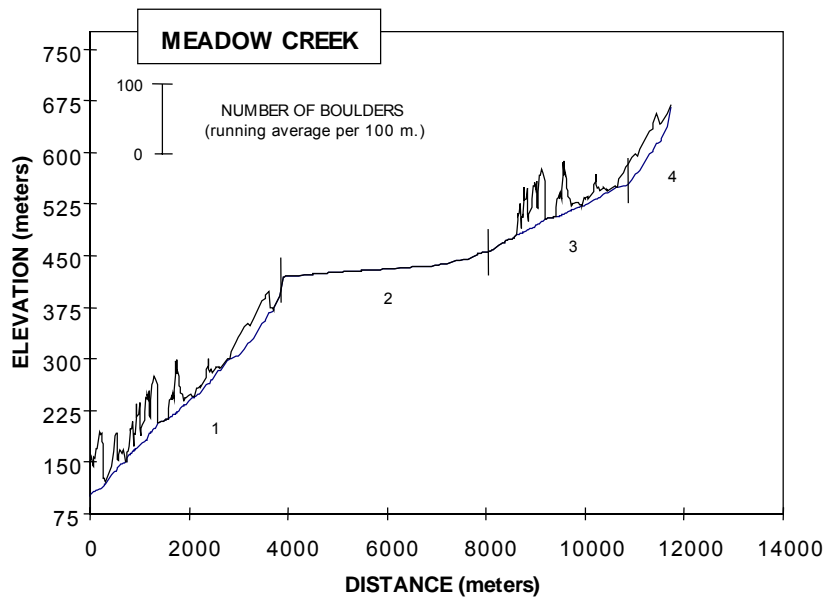

**Figure 6. Large boulders plot.** This is a trend plot, i.e., it is a general indication of the number of large boulders throughout each reach. *The plot does not indicate the actual number of boulders at any given location because it is a plot of the running average.*

- **Significance for fish habitat:**

Large boulders contribute significantly to “surface roughness.” **Surface roughness** refers to the stream’s ability to withstand the erosive force of high flows, especially during winter high flows, or unusual flood events. Surface roughness increases with the size and number of large boulders in the substrate. Large boulders are not easily moved, and may require extremely high flows for transport downstream. Upstream areas tend to have greater numbers of large boulders. Large boulders are also most common in streams flowing through narrow valleys.

Large boulders provide cover from predators, as well as resting and feeding sites for salmonids in the **pocket pools** formed in association with the boulder. Fish require little expenditure of energy to reside in pocket pools and can easily feed in faster waters nearby. Boulder-formed pockets are also used as over-wintering habitat and as shelter areas from high winter or flood flows. Boulder pockets are prime habitat for aquatic macroinvertebrates, a primary food source for salmonids.

## 6.6 Number Of Deep Pools

***Number of deep pools includes pools deeper than 0.5 meter or 1.0 meter depending on stream size. Fish use pools for resting, rearing, escaping predators, over-wintering, and as cool water refuges during the summer.***

- **What it means:**

Number and depth of deep pools is a measure of the maximum depth of deep pools in a stream at the time of the survey. In larger systems, deep pools are those with depths equal to or greater than 1.0 meter. In smaller systems, deep pools are those with depths of 0.5 meter or greater. The choice of which minimum depth to plot is based on active channel measurements or the overall depths of all pools in the survey.

- **How numbers and depth of deep pools are determined:**

The survey crew uses a depth staff calibrated in tenths of a meter to measure the depth at the deepest part of each pool. Occasionally, a pool is so deep, or the deepest part so inaccessible, surveyors must visually estimate the depth of the pool. On the rare occasions a large stream system is surveyed from a boat, canoe, or other craft, pool depths are determined with an electronic depth finder.

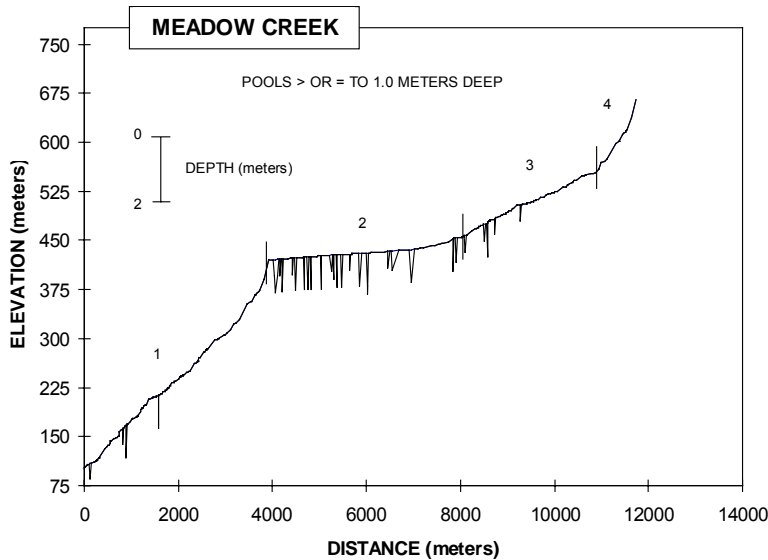

**Figure 7.** Pools deeper than 1.0 meter plot. Depth plots extend below the profile line, indicating the depth of the pools. Most of these pools are 1.0 to 1.5 meters deep.

- **Significance for fish habitat:**

Pool depth indicates the ability of a stream to provide critical habitat for salmonids. Pools are important resting areas for fish. It requires less energy to hold in pools than in fast water. Fish also find refuge from predators in pool areas. Pools are important rearing areas for many species. Pools can be critical over-wintering habitat for juvenile salmonids, and may form some of the only viable habitat during summer low flows, especially in drought years. Finally, the bottoms of pools are usually the coolest habitats in the stream, and these thermal refuges are strongly preferred by all life stages during the warm summer months. Depth enhances all of the desirable qualities of pool habitat for salmonids.

## 6.7 Pieces and Volume Of Large Wood

***Pieces and volume of large wood refer to dead and dying trees within the stream channel. Pieces must be a minimum of 15 centimeters in diameter and 3.0 meters in length, including rootwads. Large wood in the stream provides an important source of cover for fish, especially in pools. As it decomposes, large wood creates an energy source for the food chain. Wood also helps create pools and new channels.***

- **What it means:**

The number of pieces and volume of large woody debris (LWD) will be described together here due to their collective effect upon fish habitat. Large woody debris refers to all pieces of wood at least 15 centimeters in diameter and 3.0 meters in length, and larger, including all rootwads.

These pieces are found at least partially within the stream's active channel and are either natural or cut dead and dying trees.

- **How the pieces of large wood count is determined:**

Surveyors count each piece of large woody debris that falls within the acceptable size criteria in each habitat unit. Any piece with some portion of its length within the **active channel** is counted. Surveyors divide the large woody debris into diameter and length classes as they count. The total numbers of pieces for each habitat unit are summed during the data analysis. To show their distribution, large woody debris accumulations are plotted at their appropriate positions along the stream.

- **Significance for fish habitat:**

Large woody debris directly provides fish cover in all types of habitat units where it is present. It is especially effective in pools. A pool with significant amounts of large woody debris is preferred by salmonids over a pool without large woody debris. Large submerged wood with a rootwad attached provides particularly good cover for fish. The presence of large woody debris in fast water units such as riffles and rapids creates a physical barrier around which water must flow. The scour created by such flow diversions is the driving force behind the formation and maintenance of **scour pools**, and in some cases, **plunge pools**.

Decomposition of large woody debris in the stream serves as an energy source for the growth of microorganisms, which in turn are fed upon by macroinvertebrates, the main food source for salmonid fry. Many macroinvertebrates species spend part of their life cycles on large woody debris substrate.

Large accumulations of large woody debris trap gravel and create new channels, especially during periods of high flow. This increases the diversity and complexity of fish habitat.

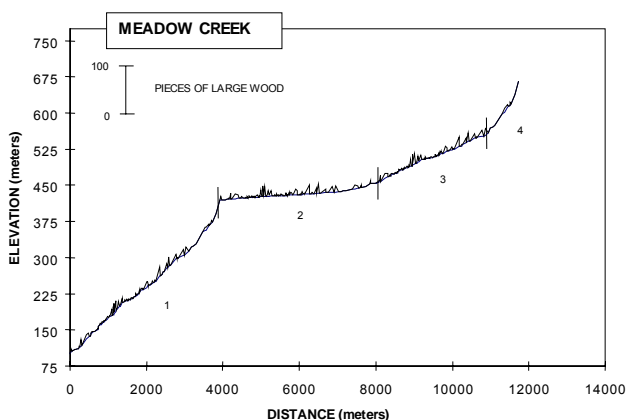

**Figure 8.** Large woody debris (LWD) plot. The presence of large diameter and/or very long pieces can result in significant volumes contributed by relatively few pieces.

## 6.8 Key Pieces Of Large Wood

**Key pieces of large wood refer to downed wood within the stream channel that is a minimum of 60 centimeters in diameter and 10 meters in length. Key pieces resist downstream transport as well as anchor and retain other pieces of wood. Key pieces represent the long-term wood retention ability of the stream.**

- **What it means:**

Key pieces of large woody debris are pieces with a minimum diameter of 60 centimeters and a minimum length of 10 meters. These pieces are dead or dying trees, either natural or cut, occurring within the stream channel. Key pieces are typically the anchor pieces around which other material is deposited and trapped.

- **How are key pieces of wood determined:**

Surveyors count each piece of large woody debris that meets the minimum size criterion in each habitat unit. Any piece with some portion of its length within the active channel is counted. Surveyors divide the large woody debris into diameter and length classes as they count. The total number of key pieces of "large" wood in each habitat unit is summed during the data analysis. To show their distribution, key pieces of large wood are plotted at their appropriate positions along the stream.

- **Significance for fish habitat:**

In general, key pieces provide identical benefits for fish habitat as those previously described for large woody debris. The overriding value of key pieces is their resistance to transport by high winter or flood flows. Key pieces enhance fish habitat by insuring long-term retention of large woody debris within the stream.

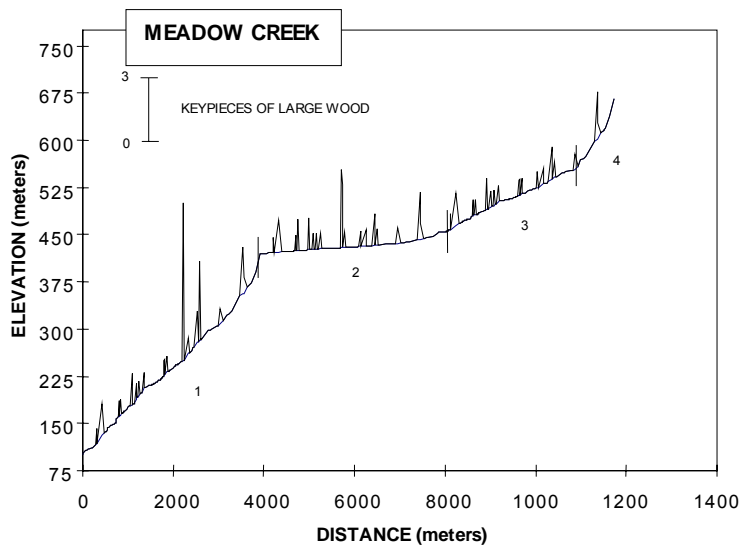

**Figure 9.** Key pieces of wood plot.

## 7.0 HABITAT BAR GRAPHS

**Habitat bar graphs show the relative surface areas occupied by different types of habitat units in a stream. The graphs are an easy way to compare the extent of different habitats, and they provide clues about a stream's ability to support different life stages of fish.**

- **What it means:**

The habitat bar graphs provide a graphical representation, in the form of histograms, of the total amount of wetted channel area for each major type of habitat unit within a reach. For example, the total area of riffle habitat is easily compared to the total area of cascade habitat. The habitat bar graphs subdivide habitat types into the following major groups:

- ⇒ **Dammed pools** - (beaver ponds, dammed pools, alcoves, backwaters, isolated pools)
- ⇒ **Scour pools** (straight scour, lateral scour, trench, and plunge pools)
- ⇒ **Glides**
- ⇒ **Riffles**
- ⇒ **Rapids**
- ⇒ **Cascades**
- ⇒ **Steps / falls**
- ⇒ **Dry units and dry channels**

- **How are habitat bar graphs determined:**

During data analysis, wetted areas for each type of habitat unit are calculated from the surveyors' measurements. The wetted area scale is plotted on the vertical or y-axis, while habitat types are aligned along the horizontal or x-axis. It is important to note that the wetted area scale is different for each reach, because the total channel area is different for each reach.

- **Significance for fish habitat:**

Habitat bar graphs create visual comparisons of the relative amounts of different habitats in a stream. This provides clues about a stream's ability to support different life stages of fish.

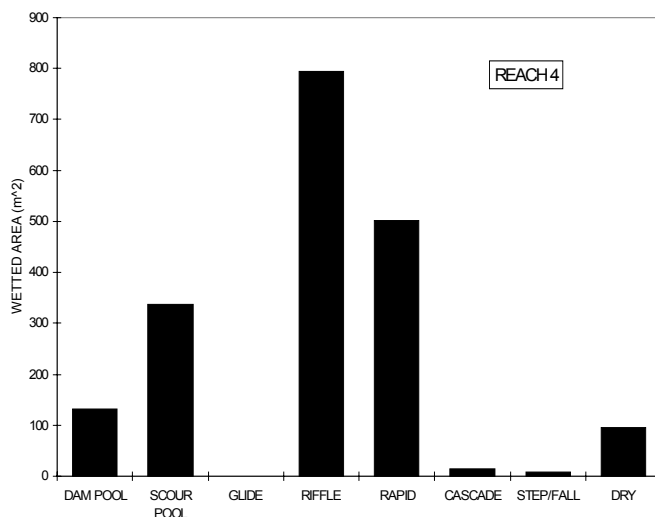

**Figure 10.** Habitat bar graph. Note the distribution of habitat types and their relative areas within this particular reach. The dominance of riffle and pool habitat is common in a reach with a low average gradient. High gradient streams have a higher proportion of rapids and cascades.

## 8.0 ADDITIONAL MATERIAL

### 8.1 Cover Document

The cover document briefly summarizes the predominant features of the stream and each reach. It includes basic information about the location of the survey, the watershed area and the ecoregion. The document discusses habitat character and any notable features in each reach such as habitat unit types, substrate, large wood loading, and potential barriers.

ODFW AQUATIC INVENTORY PROJECT			
STREAM REPORT			
STREAM:	Log Creek		
BASIN:	Mohawk Creek (McKenzie River)		
DATES:	September 22 -23, 1999		
SURVEY CREW:	Andrew Gross / Jared Weybright		
REPORT PREPARED BY:	Charles Stein		
STREAM ORDER:	2	BASIN AREA:	9.5 km <sup>2</sup> FIRST ORDER TRIBUTARIES: 2
USGS MAPS:	Mohawk		
ECOREGION:	Cascades Western Central		
HUC NUMBER:	17090004	LLID:	1227915442431
GENERAL DESCRIPTION:			
The Log Creek habitat survey begins at its confluence with Mohawk Creek and extends 3,301 meters. The stream survey encompasses private and BLM land ownership.			
REACH DESCRIPTIONS:			
Reach 1:	(T15S-R1W-S27NE) Length 3,301 meters. Reach 1 begins at the confluence with Mohawk Creek. The channel is constrained by high terraces and hillslopes within a broad valley. The average valley width index is 10.9. Land uses for the reach are large timber and rural residential homes. The average unit gradient is 1.0 percent. Stream habitat is dominated by beaver dammed pools (41%) and scour pools (39%). Stream substrate is dominated by sand and organics (65% combined) and gravel (28%). Twenty three percent of the reach length has actively eroding banks. Wood volume is 11m <sup>3</sup> /100m. The trees found most frequently in the riparian zone are a mix of coniferous and deciduous species 3 - 30 cm. dbh. (determined from 11 riparian transects).		
COMMENTS:			
The crew observed trout up to unit 106 (1,505 meters upstream from the confluence with Mohawk Creek) however upstream distribution limit was not determined.			
Extensive beaver activity was noted throughout the survey			



## 8.2 Comment Summary

The comment summary lists all the comment codes and notes made by the survey crew during the survey. Comments are listed by reach, unit number, habitat type, and distance from the beginning of the survey. The Methods Manual lists all potential comment codes.

LOG CREEK, 1999						
REACH	UNIT#	TYPE	CHAN	DIST.(m)	COMMENTS NOTE ESTIMATOR	NOTE NUMERATOR
1	1	RB	00	7	START @ CONFL W/MOHAWK R	T = 16C/1345, @ CONF W/MOHAWK
1	12	SS	01	148	CS	H = 0.2M H = .2M, RIPRAP
1	13	CC	01	164	CC	METAL CULVERT 1.8M DIAM, MOHAWK RIVER RD
1	15	SS	02		CS	H = .2M
1	16	CC	02		CC	UNDER MOHAWK CR RD 1.8M DIAM, MOHAWK RIVER RD
1	17	SD	00	168	BD	H = .65M METAL CULVERT IN GOOD SHAPE
1	18	BP	00	226	BV	HEAVY SILT, CAN'T SEE BOTTOM
1	34	SS	00	446		H = .2M H = 0.2M
1	35	CC	00	473	CC	OLD RR XING OVAL CULVERT, OLD RR XING
1	39	SD	00	501	BD	H = 0.5M OLD TIRE IN DAM
1	40	BP	00	570	BV	OLD TIRE, FENCE GATE IN CR H = .5M
1	41	SD	00	571	BD, PN	H = 1.1M, P-25/0959 H = 1.1M
1	54	RR	00	944	RF	LOW FLOW BARRIER, RD FORD LOW FLOW BARRIER
1	57	LP	00	1009	SS/	
1	63	CC	01	1091	CC, CS	DUAL CULVERT UNDER LOG CR RD LOG CR RD, 1.6M DIAM
1	65	CC	02		CS	D = 1.6M LOG CR RD, 1.6M DIAM
1	68	LP	00	1124	SD	SM BATTERY OPER. PUMP ON RT 2.5" IRRIG HOSE IN CR W/PUMP
1	72	SD	00	1151	BD	H = .3M H = .3
1	73	BP	00	1205	BV	
1	77	SD	00	1215	BD	H = .15M, MOSTLY EARTHEN DAM H = .15
1	78	BP	00	1225	BV, WL	COON TRACKS
1	83	RI	00	1262	FC	FENCE XING
1	85	RP	01	1307	TJ/	
1	86	RI	11		FC	UNMARKED TJ, ACW = 1.1M, FENCE ACW = 1.1, T = 13C/1150
1	95	LP	00	1388	WL	7" CUTTHROAT (CT) 6-7" CT, DEER TRACKS
1	106	LP	00	1505	BV	FISH, DAM START
1	107	SD	00	1506	BD	H = .15M H = .15M
1	108	BP	00	1531	BV	
1	116	LP	00	1620	BC	RIP GRV RD DRIVEWAY, LINKS PROP.
1	132	LP	00	1784	FC	FENCE XING
1	146	SL	00	1943		H = .15M RIP, FLAGGED
1	155	LP	00	2014		BLM BNDRY BLM BNDRY
1	161	SS	00	2112		H = .4M H = .4M
1	162	CC	00	2123	CC	BOWMAN'S RD, METAL CULVERT BOWMAN RD, H = 1.4M, W = 2.4M
1	172	RI	01	2211	/TJ	
1	173	DU	11			UNMARKED TRIB, ACW = 1.4M ACW = 1.4M
1	179	LP	00	2293	WL	DEER TRACKS DEER TR
1	204	SD	00	2525	BD	H = .15M H = .15
1	205	BP	01	2584	BV, TJ/	
1	206	CB	11			UNMARKED TRIB/ACW = .7/BLM FLAGG T = 7C/0900, ACW = .7M
1	208	SD	00	2593	BD	H = .3M H = .3M
1	209	BP	00	2642	BV	
1	236	SD	00	2836	BD	H = .1M H = .10, DAM START
1	237	BP	00	2849	BV	.4M DRAINAGE CULVERT/ FLAGGED, RIP
1	239	LP	00	2858	CE/	DRAINAGE FROM RD
1	260	SD	00	3125	BD	H = .1M H = .10M, BD START
1	261	BP	00	3133	BV	T = 9C/1130
1	262	SD	00	3134	BD	H = .4M H = .40
1	263	BP	01	3170	BV	/TJ T = 7.5C/1140
1	264	SD	11		BD	MARKED TRIB, T = 7.5C, H = .2M H = .20M, ACW = 1.9
1	265	BP	11		BV	ACW = 1.9M
1	279	LP	01	3276	TJ/	
1	280	SS	02		CE	H = .2M H = .2, RUSTED OUT
1	281	CC	02		CC	METAL CULVERT, D = .75M DIAM = 8C/1230, ACW = 2M
1	282	RI	11			MARKED TRIB, ACW = 2.0M T = 8C/1230, ACW = 2.0M
1	283	CC	01	3282	CC	METAL CULVERT, D = .75M .75M DIAM, RND MTAL-GOOD SHAPE
1	284	RI	00	3300		EOS, ACW = 2.5M, RIP, NO FLAG ACW = 2.7, RIP, END SURVEY

### 8.3 Maps

Topographic maps are included with each stream survey. The maps show locations for the beginning and end of the survey, reach breaks, and important features such as potential barriers, landslides, tributary junctions, and bridge crossings with the unit numbers at which these occur. (Map scales noted below are incorrect.)

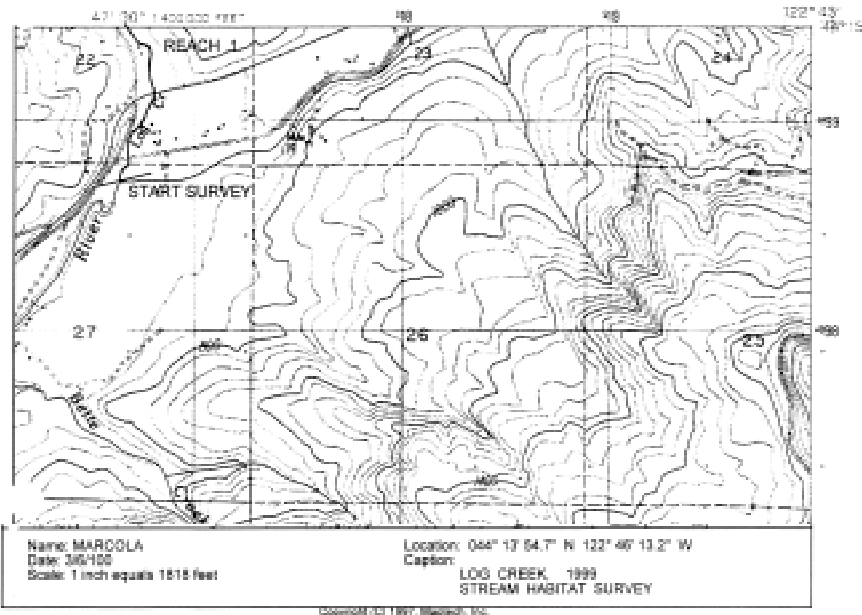
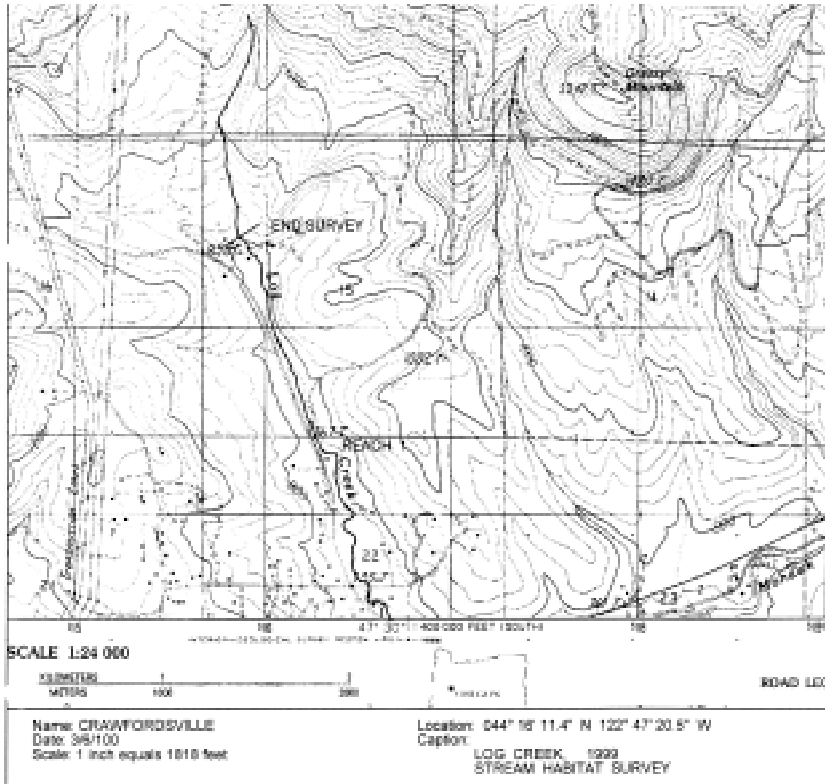

## 8.4 Photo Sheets

Photos show the character of each reach. Photos are also used to record important features of the stream. Each photo is tied to a location and habitat unit and this information is recorded on the photo sheet.

## 8.5 Calibration Worksheet (not always included with report)

A calibration worksheet is used when the survey crew estimates the length and width of each habitat unit. The crew verifies the estimates by measuring the length and width of every tenth habitat unit. During data analysis, the lengths and widths of all of the habitat units are calibrated by the verified units by summation and linear regression. A scatter plot displays the estimated lengths and widths against the measured lengths and widths.

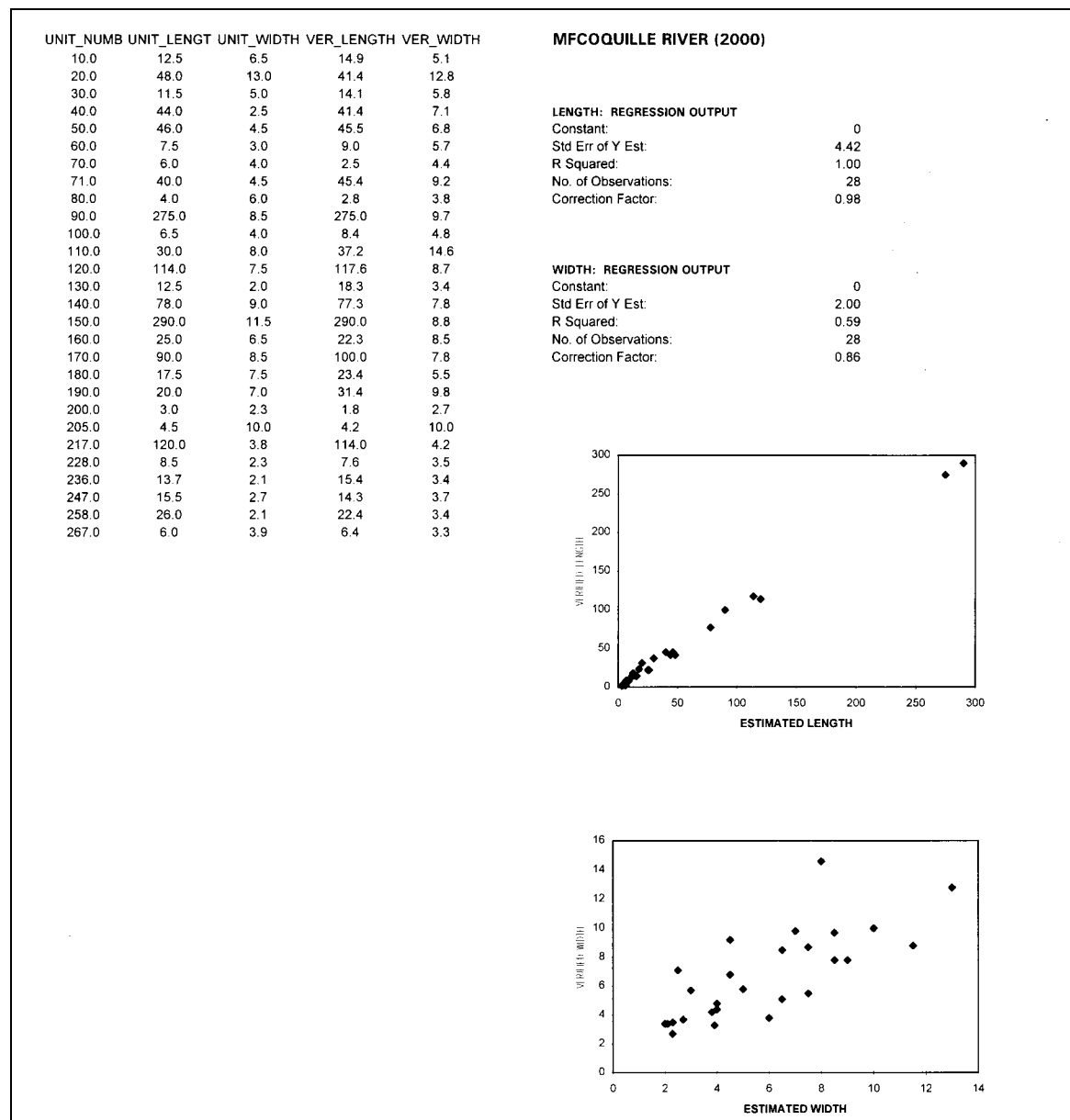

## PART B – WATERSHED LEVEL ANALYSIS

### 9.0 BASIN SUMMARY

*A discussion about a stream is not complete without viewing the stream in the context of its neighboring streams and its place in the watershed. Every stream reach does not have to fulfill all the life history requirements of each species in the fish community. View the reaches of a stream in a watershed as part of an interconnected web, each with different features, functions, and processes.*

The *Basin Summary* describes the key components of all streams surveyed within a given watershed. The summary includes information on valley and channel morphology, channel dimensions and slope, instream habitat including pools, substrate, and large wood, and riparian characteristics.

#### 9.1 Reach Summary Tables

The reach summary tables describe the habitat for each reach of stream within a watershed (Tables 1 and 2). The information is compiled directly from the Reach, Habitat Unit, and Riparian Reports.

#### 9.2 Frequency Distributions

A graphical presentation of several key components provides a comparison of values within a watershed (Figure 11). Each graph is a frequency distribution for a habitat variable such as shade, pieces of large wood, or percentage of pool habitat. The horizontal or x-axis displays the values of the variable and the vertical or y-axis displays the percentage of stream length with that value in the watershed. Notice both the median value and the range of values, and shape of the distribution. Determine, for example, what percentage of the stream miles in a watershed is above or below a given value. Frequency distribution charts depict the variability of a habitat feature throughout a watershed.

#### 9.3 Benchmarks

Benchmarks provide a method for comparing values of key components. While the natural regime of a stream depends on climate, geology, vegetation, and disturbance history, it is useful to know whether the value of a habitat feature in a reach of stream is high or low. For example, knowing whether a reach has a lot of large wood debris or fine sediments is useful when evaluating the condition of aquatic habitat and its influence on the life history of fishes. Determining whether the “value” of a habitat feature is “good” or “bad” depends on the natural regime of the stream and the fish species of interest. Values for habitat features are listed as desirable or undesirable in Table 3, but the values must be viewed on a sliding scale and the watershed context must be considered.

For example, 8 pieces of large woody debris/100m may be very low for a stream in the Cascade Mountains, but extremely high for a stream in the high desert of Southeast Oregon. The stream must be viewed within the context of its natural environment. Similarly, a reach in the Cascade Mountains may have 8 pieces of large woody debris per 100 meters, but neighboring reaches may have 25 pieces per 100 meters. Variability within a watershed reflects normal disturbance

and hydrologic cycles as well as management history. Again, the natural regime of a stream is as important as the range of values within a watershed.

The components and values in the table provide a starting point for comparing the distribution of habitat features within a watershed and their importance to fish. They are only useful when placed within the natural context of the streams in a watershed and the life history diversity of fishes.

SOUTH SANTIAM BASIN: REACH SUMMARY

1997 HABITAT SURVEYS

TABLE 1

STREAM	REACH	LENGTH (m)	% AREA IN SIDE CHANNELS	GRADIENT	CHANNEL FORM*	LAND USE*	OPEN SKY % of 180	BANK EROSION %	FINES IN RIFFLES %	GRAVEL IN RIFFLES %	LARGE BOULDERS #/100m
EAST FORK PACKERS GULCH	1	514	0.8	8.2	CH	MT	12	0.4	13	34	121
EAST FORK PACKERS GULCH	2	435	0.5	4.1	US	OG	19	0.0	10	70	8
EAST FORK PACKERS GULCH	3	962	0.7	9.2	CH	OG	19	0.4	20	55	48
EAST FORK PACKERS GULCH	4	377	0.2	12.7	CH	YT	32	0.0	11	42	81
PACKERS GULCH	1	411	7.2	3.7	CH	ST	32	5.2	5	11	52
PACKERS GULCH	2	2560	0.5	3.4	CH	ST	24	7.6	5	15	46
PACKERS GULCH	3	273	3.5	4.8	CH	ST	40	2.5	5	10	61
PACKERS GULCH	4	608	1.8	6.3	CH	ST	37	0.0	5	15	49
PACKERS GULCH	5	1190	0.6	11.9	CH	ST	11	0.1	0	15	31
THOMAS FORK OF PACKERS GULCH	1	2508	1.7	12.6	CH	ST	40	67.7	23	36	32
THOMAS FORK OF PACKERS GULCH	2	312	1.0	23.5	CH	MT	39	93.6	13	26	28
SOUTH FORK PACKERS GULCH	1	3095	0.5	11.8	CH	ST	30	9.3	8	10	46
WEST FORK PACKERS GULCH	1	1493	6.1	8.0	CH	ST	23	0.0	20	35	42
WEST FORK PACKERS GULCH	2	1619	1.8	13.4	CH	ST	18	5.3	12	15	70
WHITCOMB CREEK	1	563	9.3	3.0	CH	YT	17	7.6	5	15	45
WHITCOMB CREEK	2	573	2.1	5.2	CH	YT	27	16.9	5	15	36
WHITCOMB CREEK	3	3214	3.6	11.3	CH	MT	23	23.6	10	20	97
EAST FORK WHITCOMB CREEK	1	1281	2.1	3.7	CH	YT	15	8.4	10	33	52
EAST FORK WHITCOMB CREEK	2	3188	0.7	9.7	CH	ST	17	44.3	11	27	80

\* SEE METHODS FOR DEFINITIONS

SOUTH SANTIAM BASIN:  
REACH SUMMARY FOR 1997  
HABITAT SURVEYS

TABLE 2

STREAM	REACH	ACTIVE	CHANNEL	NUMBER	PERCENT	RESIDUAL	WOOD DEBRIS			DECIDUOUS	CONIFEROUS	RIPARIAN CONIFERS	
		CHANNEL	WIDTHS/ POOL			POOLS	POOL	PIECES	VOLUME	KEY PIECES	TREES	TREES	#>20in dbh
		WIDTH		POOLS	POOLS	DEPTH (m)	#/100m	(m3)/100m	#/100m	TOTAL/1000ft	TOTAL/1000ft	/1000ft	/1000ft
EAST FORK PACKERS GULCH	1	4.8	15	8	6	0.5	17	36	1.6	823	610	61	61
EAST FORK PACKERS GULCH	2	4.3	26	4	2	0.8	31	114	7.1	1097	610	244	0
EAST FORK PACKERS GULCH	3	5.1	8	25	17	0.5	38	113	6.7	163	589	122	81
EAST FORK PACKERS GULCH	4	3.8	52	2	2	0.4	27	89	5.3	122	610	0	0
PACKERS GULCH	1	11.5	7	6	23	1.0	13	17	0.5	1341	610	0	0
PACKERS GULCH	2	9.0	6	46	28	1.0	13	15	0.1	1853	610	0	0
PACKERS GULCH	3	10.0	7	4	21	0.7	6	5	0.4	2195	1524	0	0
PACKERS GULCH	4	7.0	18	5	9	0.4	5	3	0.0	1707	549	0	0
PACKERS GULCH	5	4.4	12	23	14	0.8	27	49	0.3	1372	579	0	0
THOMAS FORK OF PACKERS GULCH	1	6.1	13	32	11	0.7	12	16	0.3	610	1097	0	0
THOMAS FORK OF PACKERS GULCH	2	4.0	27	3	7	0.7	3	9	0.0	427	305	0	0
SOUTH FORK PACKERS GULCH	1	6.9	10	44	13	1.1	8	20	0.8	772	396	41	20
WEST FORK PACKERS GULCH	1	7.8	5	40	25	0.8	14	30	1.5	1326	488	0	0
WEST FORK PACKERS GULCH	2	6.5	15	18	10	1.0	16	66	3.1	366	457	122	30
WHITCOMB CREEK	1	16.0	10	5	19	0.7	11	16	1.1	2438	122	0	0
WHITCOMB CREEK	2	11.8	10	5	16	0.7	10	22	1.4	183	305	0	0
WHITCOMB CREEK	3	8.4	16	25	11	0.7	13	35	1.7	0	671	61	30
EAST FORK WHITCOMB CREEK	1	7.4	10	18	20	0.6	15	39	2.3	1158	792	0	0
EAST FORK WHITCOMB CREEK	2	5.9	18	30	12	0.8	23	40	1.5	1158	264	61	41

**NEHALEM RIVER BASIN  
ECOREGION: COAST RANGE VOLCANIC**

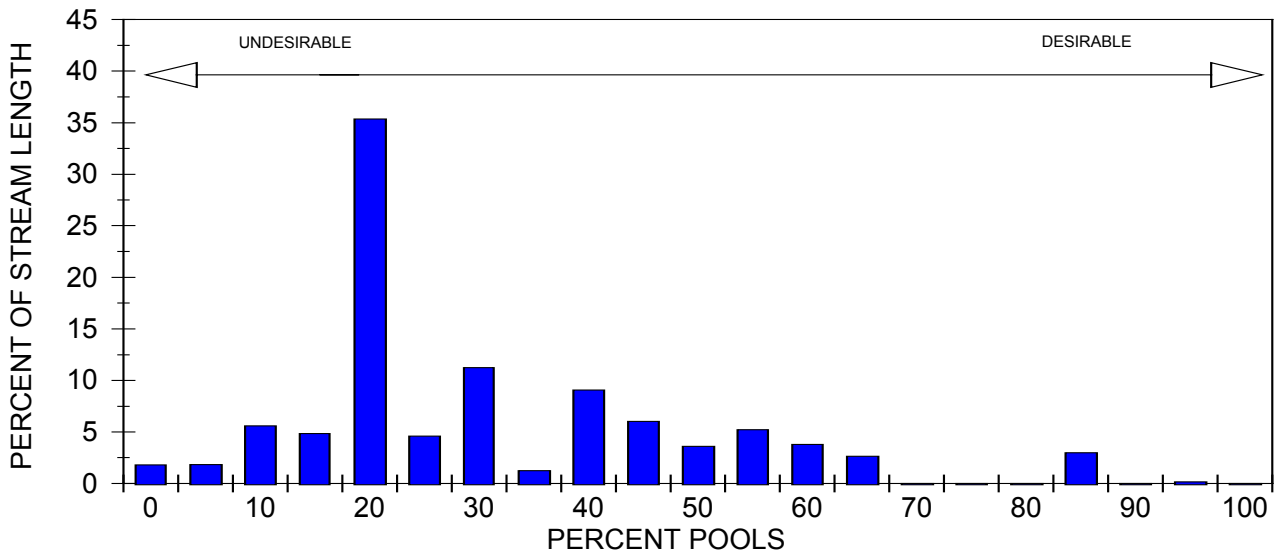

**NEHALEM RIVER BASIN  
ECOREGION: COAST RANGE VOLCANIC**

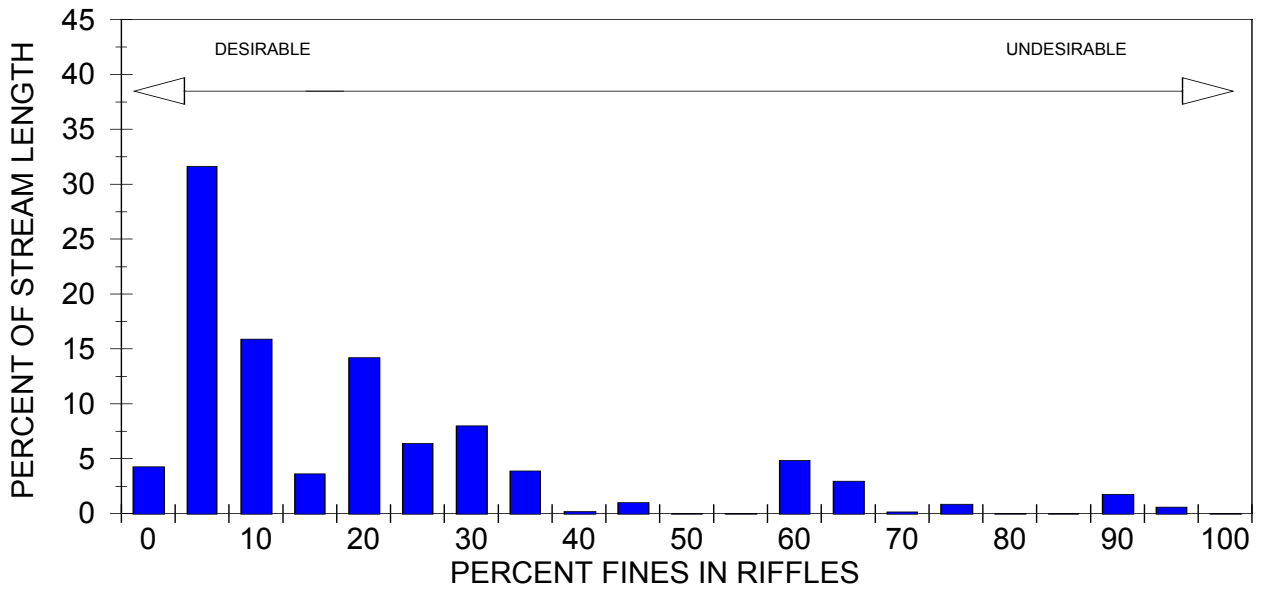

**Figure 11.** Examples of frequency distributions for percent pools, and percent fine sediments in riffles, within a basin.



**Table 3.** ODFW Aquatic Inventory and Analysis Project: Habitat Benchmarks.

<u>POOLS</u>	<u>UNDESIRABLE</u>	<u>DESIRABLE</u>
POOL AREA (% Total Stream Area)	<10	>35
POOL FREQUENCY (Channel Widths Between Pools)	>20	5-8
RESIDUAL POOL DEPTH (m)		
SMALL STREAMS (<7m width)	<0.2	>0.5
MEDIUM STREAMS (≥ 7m and < 15m width)		
LOW GRADIENT (slope <3%)	<0.3	>0.6
HIGH GRADIENT (slope >3%)	<0.5	>1.0
LARGE STREAMS (≥15m width)	<0.8	>1.5
COMPLEX POOLS (Pools w/ LWD pieces ≥3) / km	<1.0	>2.5
<u>RIFFLES</u>		
WIDTH / DEPTH RATIO (Active Channel Based)		
EAST SIDE	>30	<10
WEST SIDE	>30	<15
GRAVEL (% AREA)	<15	≥35
SILT-SAND-ORGANICS (% AREA)		
VOLCANIC PARENT MATERIAL	>15	<8
SEDIMENTARY PARENT MATERIAL	>20	<10
CHANNEL GRADIENT <1.5%	>25	<12
<u>SHADE</u> (Reach Average, Percent)		
STREAM WIDTH <12 meters		
WEST SIDE	<60	>70
NORTHEAST	<50	>60
CENTRAL - SOUTHEAST	<40	>50
STREAM WIDTH >12 meters		
WEST SIDE	<50	>60
NORTHEAST	<40	>50
CENTRAL - SOUTHEAST	<30	>40
<u>LARGE WOODY DEBRIS* (15cm x 3m minimum piece size)</u>		
PIECES / 100 m STREAM LENGTH	<10	>20
VOLUME / 100 m STREAM LENGTH	<20	>30
“KEY” PIECES (>60cm dia. & ≥10m long)/100m	<1	>3
<u>RIPARIAN CONIFERS (30m FROM BOTH SIDES CHANNEL)</u>		
NUMBER >20in dbh/ 1000ft STREAM LENGTH	<150	>300
NUMBER >35in dbh/ 1000ft STREAM LENGTH	<75	>200

\* Values for Streams in Forested Basins

## **APPENDIX I: SUMMARY OF ODFW STREAM SURVEY METHODOLOGY**

The process of conducting a stream survey involves the detailed observation of stream characteristics in the field. Data are collected on a variety of spatial scales including basin, stream, reach, habitat unit, and subunit scales. This variety allows analyses of survey data to be conducted within the context of the network of streams that comprise a basin or watershed, as well as allowing data to be collected with high resolution.

Stream surveys are typically conducted during the summer months for a variety of practical reasons, including physical access, low flows, and improved visibility through the water. However, fall, winter, and spring surveys are also conducted as data needs arise. The methods used by the Aquatic Inventories Project are suitable for small- and medium-size streams throughout Oregon, from southeastern desert basins, through the coastal rain forests.

A field survey crew has two persons, each of whom is responsible for individual and shared tasks. The “estimator” is responsible for determining lengths, widths, slopes, channel configurations, and shading of each habitat unit. The “numerator” is responsible for determining depths, substrate distributions, bank characteristics, length and width verifications, and map work. The crew members are jointly responsible for determining valley and channel characteristics, determining channel metrics, measuring distributions of large woody debris, and for conducting riparian transects to sample the streamside plant community. One or more supervisors may work with the crews for training, quality control, and problem resolution purposes.

A stream or section of stream to be surveyed is subdivided into larger spatial domains called reaches, which are differentiated from one another by changes in land use or ownership, valley or channel characteristics, the presence of major tributaries or barriers to fish passage, or other factors. Within each reach, the surveyors subdivide the stream into habitat units, which are defined based upon physical criteria such as slope, bedform, substrate, depth, and channel configuration. These affect how fish will use that section of stream at various points in their life histories. The surveyors collect a complete set of detailed data for each habitat unit. The sizes of habitat units are scaled to the size of the stream, which helps eliminate stream size as a variable in subsequent analysis of the data. Each habitat unit is immediately adjacent to the next, so that data are collected in a continuous manner throughout the survey. By georeferencing at known points or with a global position system (GPS), the survey crew links this continuous data set to USGS 7.5 minute topographic maps.

At the reach level, the crew determines the valley configuration of each consecutive reach based in part upon the width of the stream channel in relation to the width of the entire stream valley. Adjacent landforms are identified, and their ability to constrain the lateral movement of the stream is measured. This information is used to determine the channel configuration of the reach. Streamside vegetation and land use are also used to identify the reach characteristics. Photographs are taken within each reach, and cross-sectional diagrams are included to supplement the other data.

At the habitat unit level, the crew determines the type and extent of each consecutive habitat unit. The length and width of each unit are either measured directly, or estimated and verified every tenth unit. Generally, a habitat unit must be longer than the width of the active channel. A clinometer is used to measure the surface slope of the water, as well as the angle of the shade on each side of the stream. A depth staff is used to measure the depths of units and subunit

features, such as the tailout depths of pools. The proportion of substrate particle sizes is estimated visually, and the numbers of large boulders are counted directly. The extents of bank erosion and bank undercut are estimated for each side of the stream. The heights and widths of the active channel, floodprone areas, and terraces are measured every tenth unit. The positions of important structures, barriers, or known locations are linked to a specific unit number by the crew. Notations are also made of anecdotal information, such as the presence of wildlife, unusual configurations, or human impacts.

Large woody debris is recorded by the crew in every habitat unit as the numbers of pieces of LWD in different diameter and length classes. The location and configuration of the wood within the channel is also recorded.

Riparian plant communities are sampled by extending a transect perpendicular to both sides of the stream channel at regular intervals. These transects are 30 meters long by 5 meters wide. The numbers and sizes of all live trees are recorded in each of three 10-meter-long zones within these transects. Canopy closure, and shrub/grass/forb ground cover are estimated visually. The landform and its slope are identified and measured for each of the three zones.

A stream survey requires the simultaneous collection of a wide variety of data regarding the physical habitat of fish. The continuous and multiple-scale nature of the data set maximizes our ability to understand how the different life stages of various species might use the instream habitat.

## APPENDIX II: GLOSSARY

**Active channel** - Active channel refers to the width and depth of a stream channel at “normal” high winter flow, sometimes also known as bankfull flow. The active channel is a key measurement from which many other measurements and statistics are scaled. Active channel flow has a reoccurrence interval of 1.5 years.

**Alcove** - An alcove is a protected type of subunit pool. Alcoves are found along the sides of the stream outside the active channel margin, generally within an adjacent low terrace. Alcoves maintain their contact with the wetted portion of the stream channel.

**Alevins** - Alevins are newly hatched fish with a connected yolk sac. Nutrients are absorbed from the yolk sac. In salmonids, this life stage is completed in spaces within the spawning gravel.

**Anadromous** - Referring to fish, an anadromous species is one that spawns in fresh water, and spends another part of its life cycle in salt water. Almost all Pacific salmon and trout (genus *Onchorynchus*) are anadromous.

**Backwater Pool** - A backwater pool is found along the channel margins. It is created by eddies around boulders, root wads, or woody debris. Backwater pools are within the active channel at most flows.

**Base flow** - Base flow is groundwater input into a stream channel and is exclusive of direct or surface runoff.

**Beaver pond** - A beaver pond is a special type of pool habitat unit. Beaver ponds are formed by the impoundment of water behind beaver dams.

**Bedrock** - Bedrock is the parent rock from which stream substrate particles are formed. Weathering, and the action of living organisms upon bedrock, forms both stream substrates and terrestrial soils.

**Cascade** - A cascade is a type of fast-water habitat. Cascades are units with gradients of 3.5 to 10.0 percent or higher. Cascades have lots of surface turbulence, accompanied by high velocity flow. Many cascades are composed of step-pool sequences, which are small pools occurring between nearly vertical hydraulic jumps.

**Channel metrics** - Channel metrics are the measurements of height and width of the active channel, floodprone area, and terrace.

**Clinometer** - A clinometer is an instrument used to measure vertical angles. It is used to measure unit gradients and stream shading provided by vegetation or topography. It is also used with trigonometry to measure the heights of objects like buildings or trees.

**Cobble** - Cobble refers to medium-large particles in the stream substrate. Cobble particles range in size from baseball to bowling ball, representing approximate diameters from 64 to 256 millimeters.

**Constrained** - A stream channel is constrained when its lateral movement is restricted by landforms or structures. Constrained stream channels have a relatively fixed position within the valley over time.

**Dammed pool** - A dammed pool is a slow-water habitat unit. Dammed pools are formed by the impoundment of water behind natural or man-made debris dams.

**DBH** - DBH refers to tree diameter at breast height, about 1.5 meters (5 feet) up from the base of the tree. DBH is a standard point of measurement used in timber surveying.

**Debris jam** - A debris jam is an accumulation of woody debris, gravel or other substrate, or material from a mass failure deposited in a specific location. The debris forms a blockage that the stream must flow through or around. Debris jams often occur in areas where the channel is constricted by such features as rocky outcrops. Debris jams occasionally form around man-made structures, such as bridge supports or car bodies. Debris jams usually span most of the stream channel's width.

**Dry unit** - A dry unit is a special type of habitat unit. Dry units may have any gradient and although they may have subsurface flow, they are dry at the time of the survey. Dry units occur between wetted units.

**Dry channel** - A dry channel is a special type of habitat unit. Dry channels are completely dry at the time of the survey. They are found in either main or secondary channels.

**Embeddedness** - Embeddedness is the degree to which large substrate particles, typically gravels, are surrounded or covered by smaller particles of silt, sand, or small gravels.

**Entrenchment** - Entrenchment describes the process of a stream cutting its channel downward below the level of the surrounding landforms. As entrenchment increases, a stream's ability to interact with its floodplain decreases.

**Floodplain** - A floodplain is a relatively wide, flat, low-lying area adjacent to the stream channel. It is inundated when the stream overflows its banks during flood flows.

**Floodprone** - Floodprone describes the height and width of an area above and beyond the stream channel that would be inundated by a flood that has a recurrence interval of approximately 50 years.

**Fry** - Fry are tiny fish that have newly emerged from the spawning gravel. Because nutrients in the yolk sac are exhausted, fry must actively seek their own food. Their diet consists of small macroinvertebrates during this life stage.

**Glide** - A glide is a type of fast water habitat unit. A glide has a 0.5 percent gradient. Glides have a uniform cross-section and no surface turbulence. In contrast to pools, glides have no significant scour or deposition. In contrast to riffles, glides have no surface turbulence.

**GPS** - Global Positioning System. A GPS unit uses satellites to pinpoint a position on the earth's surface. GPS units are often used to note starting and ending points of reaches, important stream habitat features, and, with a compass, for general land navigation.

**Gradient** - The gradient of a stream is the slope of the water's surface. It is the measure of a stream's steepness.

**Gravel** - Gravels are intermediate-sized particles found in a stream's substrate. Particles from 2–64 mm in diameter (roughly pea to baseball sized) are referred to as gravel. Salmonids use gravels for spawning and incubation of eggs.

**Habitat unit** - A habitat unit is the basic subdivision of the stream channel. Each habitat unit is characterized by a relatively uniform gradient, substrate, and cross-sectional profile. Habitat units form a continuous chain from the beginning to the end of the survey. With a few exceptions, habitat units are at minimum as long as the active channel is wide. Thus, in small streams, each habitat unit may be only a few meters long, while in large streams, habitat units may be 25 or more meters long.

**Harborage** - Harborage is any subset of fish habitat where fish can escape from predators, avoid high flow velocities, or rest. Typical harborage areas include undercut banks, submerged root wads, bottoms of pools, or waterfall bubble curtains.

**Interstitial spaces** - Interstitial spaces are small spaces between objects, i.e., such as the spaces between gravels, cobbles, or boulders, or between pieces of large wood. These areas are used by different life stages of fish and are often key areas for aquatic insect colonization.

**Isolated pool** - Pools existing outside the wetted channel but within the active channel are called isolated pools.

**Key pieces** - Key pieces are substantial pieces of large woody debris (LWD). Some part of the piece must lie within the active channel of the stream. Key pieces are at a minimum 60 centimeters (24 inches) in diameter and 10 meters (34 feet) in length.

**Large boulders** - Large boulders are at least 0.5 meter (20 inches) in diameter, are part of the stream's substrate, and have some part extending above the water's surface at the time of the survey.

**Large wood (LWD)** - Large woody debris (LWD) includes pieces of wood, either natural or cut, with some part of the piece within the active channel of the stream. The minimum size for counting a piece of LWD is 15 centimeters (6 inches) in diameter by 3 meters (10 feet) in length. The minimum length does not apply to root wads.

**Macroinvertebrates** - Macroinvertebrates are aquatic invertebrate organisms large enough to be seen with the naked eye. They either live within or upon the substrate, although some forms may be free-floating. Macroinvertebrates comprise the principal diet of juvenile salmonids. Typical macroinvertebrates are immature insects such as mayfly or caddisfly larvae, or stonefly nymphs. Crustaceans, isopods, and other groups are also considered macroinvertebrates.

**Mass failures** - A mass failure is an area where the hillslope or terrace adjacent to the stream channel has lost its structural ability to resist the force of gravity. The area gradually or quickly moves downhill toward or into the stream channel. Types of mass failures are earthflows, landslides, and avalanches.

**Microhabitats** - Microhabitats are small areas used by fish or other organisms for feeding, resting, and avoiding predators.

**Off-Channel** - Off-channel areas are habitat units located away from and along the main channel. They include secondary channels or flood overflow channels, as well as backwater, isolated, or alcove pools. Off-channel areas are important to salmonids during different parts of their life cycles.

**Plunge pool** - A plunge pool is a type of slow water habitat unit. Plunge pools are formed by the vertical force of water plunging over an object, such as a boulder, piece of large wood, bedrock shelf, culvert, or other structure. The plunging action usually scours a deep section of the pool at its upstream end.

**Pocket pools** - Pocket pools are small pool areas within larger habitat units (i.e., riffle with pockets). They are formed by the scouring action of water accelerating around an instream obstacle, such as a boulder or a root wad.

**Primary channel** - The primary channel of a stream carries the majority of the stream flow. In many streams, it is the only wetted channel during the summer months. Some stream configurations, such as unconstrained braided streams, have no single primary channel.

**Profile** - A profile is a graph that displays the relationship between elevation rise and length of the stream. It pictorially displays the gradient of the stream. The relative amounts and distribution of habitat variables can be displayed graphically.

**Rapid** - A rapid is a type of fast-water habitat unit. Rapids are units with moderately high gradients of 3.0 to 8.0 percent, occasionally greater. Rapids have significant surface turbulence created by high velocity flow and the formation of eddies and hydraulic jumps around cobbles and boulders.

**Reach** - A reach is a large subdivision of a stream determined by a fairly uniform set of valley, channel, and land use characteristics. Each reach encompasses many smaller individual habitat units.

**Redds** - Redds are the nesting sites where salmonids deposit and fertilize their eggs during spawning. Redds are constructed by the female in various sized gravels, specific to each species.

**Riffle** - A riffle is a type of fast-water habitat unit. Riffles have a gradient of 1.0 to 4.0 percent. Riffles are usually shallow, with a uniform cross-section. The substrate in a riffle is generally composed of gravel or cobble.

**Riparian area** - A riparian area is a terrestrial zone alongside the stream channel directly influenced by the water of the stream. It is sometimes called the green zone. Annual and intermittent water, a high water table, and wet soils influence vegetation and microclimate in a riparian area.

**Salmonids** - Members of the Salmonidae family. In Oregon, native salmonids include Pacific salmon, genus *Oncorhynchus* (coho, chinook, sockeye, chum, and pink salmon, rainbow and steelhead trout, and cutthroat trout), a char, genus *Salvelinus* (bull trout), and whitefish,

genus *Prosopium*. Introduced salmonids include Atlantic salmon, brown trout, brook trout, and lake trout.

**Scour pool** - A scour pool is a type of slow-water habitat unit. Scour pools are formed by scouring, or erosion through hydraulic forces, of substrate from the stream channel, and deposition of that material elsewhere. Deposition may occur on the sides of the pool, at the downstream end of the pool, forming a tailout, or be transported further downstream. The scoured area forms the pool. Scour pools are divided into two types: lateral scour and straight scour pools, and are classified according to the positions of scour. Lateral scour pools have the deepest scour on the side of the pool, while straight scour pools have the deepest scour down the middle. Lateral scour pools are most common.

**Secondary channels** - Secondary channels are all channels other than the main, or primary, channel of a stream.

**Silt and organics** - Silt and organics are the smallest substrate particle sizes, including particles from microscopic to .062 millimeter in diameter.

**Step / falls** - A step is a special type of habitat unit. Steps are characterized by discrete breaks in the gradient of the stream. Steps are the most vertical of the habitat units. The vertical extent of a step may range from as low as 30 centimeters (1 foot) to as high as the highest waterfall. The heights of steps are usually measured instead of the gradients. Steps are usually wider than they are long. Steps can occur over a variety of objects or surfaces, including bedrock outcrops, logs, cobble bars, boulders and culverts.

**Substrate** - The substrate is the material that makes up the bottom of the stream channel. Substrate is usually characterized by particle size.

**Terrace** - A terrace is a landform created by the deposition of material from a flowing stream, usually during high flow events. The stream subsequently cuts its channel down into the deposited material, creating terraces beside the stream channel. Terraces tend to be flat on the top.

**Thalweg** - Path of a stream that follows the deepest part of the channel.

**Trench pool** - A trench pool is a type of slow-water habitat unit. Trench pools are formed in bedrock substrates. They are often deep and narrow, as the name implies.

**Unconstrained** – A term referring to a stream channel that is not restricted by adjacent landforms or structures. Unconstrained stream channels have a variable position on the valley floor over time.

**Undercut** - Undercut refers to stream banks where the wetted channel cuts laterally underneath the surface of a bank. The roots of vegetation usually stabilize undercut banks. Undercut banks are also known as “overhanging” banks.

**UTM** - Universal Transverse Mercator, part of an international map reference system. UTM readings from a global positioning device (GPS) are standard units used to pinpoint locations on a topographic map.



**Valley width index (VWI)** - The valley width index is a measurement defined as the ratio of the valley width to the active channel width. In other words, the VWI represents the number of active channels that will fit across the valley floor.

**Verified** - Verified refers to habitat units which are measured for length and width to calibrate the units whose lengths and widths are estimated.

## LITERATURE CITED

- Bisson, P., J. Nielsen, R. Palmasono, and E. Grove. 1982. A system of naming habitat types in small streams, with examples of habitat utilization by salmonids during low stream flow. Pp. 62-73 in N. B. Armantrout, ed. *Acquisition and utilization of aquatic habitat inventory information*. American Fisheries Society, Western Division, Bethesda, Maryland.
- Cummins, K., and M. Klug. 1979. Feeding ecology of stream invertebrates. *Annual Review of Ecology and Systematics*. 10: 147-72.
- Everest, F., R. Beschta, J. Scrivener, K. Koski, J. Sedell, and C. Cedarholm. 1987. Fine sediment and salmonid production: A paradox. Pp. 98-142 in E.O. Salo and T.W. Cundy, eds. *Streamside Management: Forestry and Fishery Interactions*. University of Washington, Seattle.
- Hankin, D., and G. Reeves. 1988. Estimating total fish abundance and total habitat area in small streams based on visual estimation methods. *Canadian Journal of Fisheries and Aquatic Sciences*. 45: 834-44.
- Moore, K., K. Jones, and J. Dambacher. 1997. Methods for stream habitat surveys. *Oregon Department of Fish and Wildlife Information Report 97-4*.
- Rosgen, D. L. 1994. A classification of natural rivers. *Catena*. 22: 169-199.